



Specification sheet

Fire Pump Drive Engine

CFP59-F40



Description

Engine Series - Cummins B5.9 Series

Exhaust Emissions - Non-certified

When performance matters, we take notice. Our engines are an assurance of safety specifically designed to fit your needs. The CFP59 engine is built to last. With over 12,000 installations worldwide, the painstaking attention to detail in the design makes this engine reliable and durable. It'll be on the job, ready to start every day for years to come.

Features

Certified Power - The CFP59-F40 complies with NFPA 20 and is UL 1247-listed and FM 1333-approved.

Control System - The industry-leading, state-of-the-art Fire Pump Digital Panel (FPDP) provides total fire pump drive engine system integration and intuitive operation, including:

- Color touchscreen;
- Dual microprocessors for critical signal redundancy;
- Standard J1939 parameter and Cummins fault code display;
- Engine idling;
- Electronic Control Module (ECM) self-diagnosis; and
- Optional Modbus[®] protonode remote messaging capability.

Warranty and Service - Our models are backed by a comprehensive warranty and worldwide distributor network.

| Operating Speed (RPM) | Ratings in HP (kW) | | | |
|-----------------------|--------------------|-------|------|-------|
| | 1470 | | 1760 | |
| CFP59-F40 | 150 | (112) | 171 | (128) |

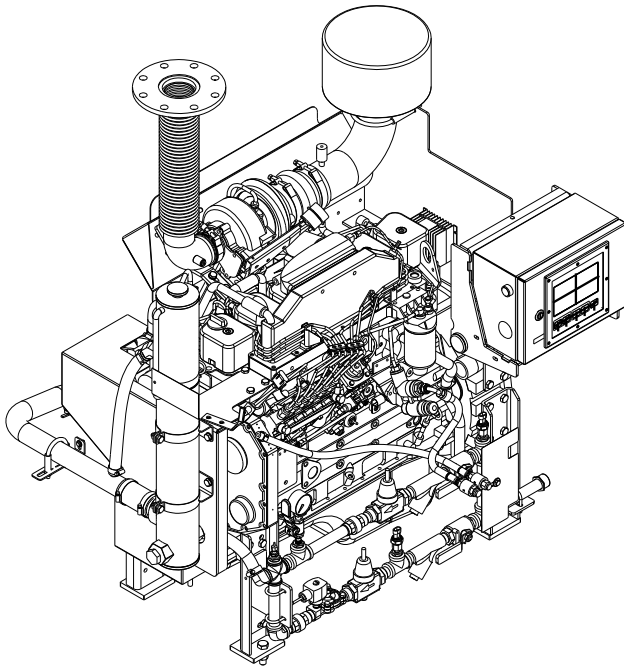

General Engine Data

| Engine Family | Industrial |
|---|------------------------------------|
| Engine Type | 4 Cycle; In-Line, 6 Cylinder |
| Aspiration | Turbocharged and After-cooled |
| Bore and Stroke | 4.02 x 4.72 in. (102 x 120 mm) |
| Displacement | 359 in ³ (5.9 L) |
| Rotation | Counterclockwise from flywheel end |
| Compression Ratio | 16.5:1 |
| Valves per Cylinder | Intake - 1 Exhaust - 1 |
| Fuel System | Bosch Mechanical |
| Maximum Allowable Bending Moment @ Rear Face of Block | 1000 lb.-ft. (1356 N-m) |
| Estimated Wet Weight* | 1760 lbs. (798 kg) |

* Weight includes engine, cooling loop, heat exchanger, dual Electronic Control Modules (ECMs), Fire Pump Digital Panel (FPDP), standard air cleaner, standard exhaust flex, and all fluids.

| Equipment | Standard | Optional |
|--|--|---|
| Air Cleaner | Disposable; treated for high humidity, indoor service | Heavy-duty, two-stage with replaceable elements |
| Alternator | 12V-DC, 95 amps; includes belt guard | 24V-DC, 45 amps with belt guard |
| Cooling Loop (maximum pressure of 300 PSI) | 3/4" diameter for fresh water; includes alarm sensors and FM-approval | Cu Ni construction available for sea water applications; approved loops up to 1 1/4" |
| Cooling System | Tube and shell type, 60 PSI with NPTF connections | N/A |
| Engine Heater | 120V-AC, 1500 watts | 240V-AC, 1500 watts |
| Exhaust Protection | Metal guards on manifolds and turbocharger | N/A |
| Exhaust Flex Connection | Stainless steel flex, NPT | Stainless steel flex, 150# flange |
| Flywheel Power Take-Off | Flywheel | Driveshaft system; stub shaft |
| Fuel Connections | Fire-resistant flexible supply and return lines | N/A |
| Fuel Filter | Primary filter with priming pump | N/A |
| Governor, Speed | Constant speed | N/A |
| Fire Pump Digital Panel (FPDP) | 7" color touchscreen; enclosure rated as Type 2/ Type 4X; Imperial and metric values | Optional 316SS construction; custom gauges with digital panel expansion module (DPEM) |
| Lube Oil Cooler | Engine-water-cooled, plate type | N/A |
| Lube Oil Filter | Full-flow with by-pass valve | N/A |
| Lube Oil Pump | Gear-driven | N/A |
| Manual Start Controls | On FPDP and/or contactors | N/A |
| Overspeed Controls | Electronic with reset and test on FPDP | N/A |
| Starter | 12V-DC | 24V-DC |

Air Induction System

| | |
|---|--|
| Maximum Temperature Rise Between Ambient Air and Engine Air Inlet | 30 °F (16.7 °C) |
| Maximum Inlet Restriction with Dirty Filter | 25 in. H ₂ O (635 mm H ₂ O) |
| Recommended Air Cleaner Element - (Standard) | Cummins Filtration AH1140 |
| Recommended Air Cleaner Element - (Heavy Duty) | Optional: primary element AF26124; secondary element AF26125 |

Lubrication System

| | |
|----------------------------------|---------------------------|
| Oil Pressure Range at Rated | 40-60 PSI (276-414 kPa) |
| Oil Capacity of Pan (High - Low) | 15-13 qt. (14.2-12.3 L) |
| Total System Capacity | 4.3 gal. (16.3 L) |
| Recommended Lube Oil Filter | Cummins Filtration LF3959 |

Cooling System*

| | |
|---|-----------------------|
| Raw Water Working Pressure Range at Heat Exchanger | 60 PSI (413 kPa) MAX |
| Recommended Minimum Water Supply Pipe Size to Heat Exchanger | .75 in. (19.05 mm) |
| Recommended Minimum Water Discharge Pipe Size From Heat Exchanger | 1.00 in. (25.40 mm) |
| Coolant Water Capacity (Engine Only) | 4 gal. (15.1 L) |
| Standard Thermostat - Type | Modulating |
| Standard Thermostat - Range | 180-203 °F (82-95 °C) |
| Minimum Raw Water Flow: | |
| - with Water Temperatures to 60 °F (16 °C) | 28.7 GPM (1.81 L/sec) |
| - with Water Temperatures to 80 °F (27 °C) | 30.2 GPM (1.91 L/sec) |
| - with Water Temperatures to 100 °F (38 °C) | 32 GPM (2.02 L/sec) |

* A jacket water heater is mandatory on this engine. The recommended heater wattage is 1500 down to 40 °F (4 °C)

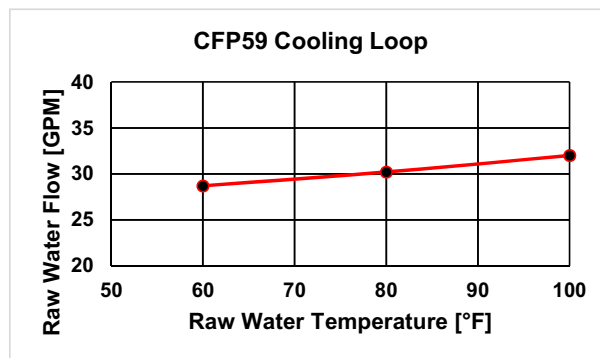

Exhaust System

| | |
|--|--------------------------------------|
| Maximum Allowable Back Pressure by Complete Exhaust System | 40.8 in. H ₂ O (10.2 kPa) |
| Exhaust Pipe Size Normally Acceptable | 4 in. (102 mm) |

Noise Emissions - The noise emission values are estimated sound pressure levels at 3.3 ft. (1 m).

| | |
|------------|-----------|
| Top | 99.0 dBa |
| Right Side | 96.3 dBa |
| Left Side | 98.9 dBa |
| Front | 96.3 dBa |
| Exhaust | 116.0 dBa |

Fuel Supply/Drain System

| Operating Speed in RPM | 1470 | | 1760 | |
|---|--|------------|------------|--|
| | Fuel Rate - Gal/hr (L/hr) | 7.2 (27.4) | 8.4 (31.7) | |
| Fuel Type | No. 2 diesel only | | | |
| Minimum Supply Line Size | 0.25 in. (6.35 mm) | | | |
| Minimum Drain Line Size | 0.125 in. (3.18 mm) | | | |
| Maximum Fuel Height above C/L Fuel Pump | 71 in. (1.8 m) | | | |
| Recommended Fuel Filter - Primary | Cummins Filtration FS1251 | | | |
| Recommended Fuel Filter - Secondary | None | | | |
| Maximum Restriction @ Lift Pump-Inlet - With Clean Filter | 4.0 in. Hg (102 mm Hg) | | | |
| Maximum Restriction @ Lift Pump-Inlet - With Dirty Filter | 8.0 in. Hg (203 mm Hg) | | | |
| Maximum Return Line Restriction - Without Check Valves | 20 in. Hg (508 mm Hg) | | | |
| Minimum Fuel Tank Vent Capability | 12 ft ³ /hr (0.36 m ³ /hr) | | | |
| Maximum Fuel Temperature @ Lift Pump Inlet | 160 °F (71 °C) | | | |

Starting and Electrical System

| Min. Recommended Battery Capacity - Cold Soak at 0 °F (-18 °C) or Above | 12V | 24V |
|---|--------------|--------------|
| Engine Only - Cold Cranking Amperes | 900 CCA* | 900 CCA* |
| Engine Only - Reserve Capacity | 430 minutes* | 430 minutes* |

*Based on FM requirement for a minimum of 900 CCA and 430 Reserve Capacity Minutes

| Battery Cable Size - Minimum of 2/0 AWG and Maximum Cable Length Not to Exceed 6 ft. (1.5 m) | 12V | 24V |
|--|------------|------------|
| Maximum Resistance of Starting Circuit | 0.002 Ohms | 0.002 Ohms |
| Typical Cranking Speed | 120 RPM | 120 RPM |
| Alternator (Standard), Internally Regulated | 95 amps | 45 amps |

Operating Conditions

| Operating Speed in RPM | 1470 | | 1760 | |
|--|-------------------|------------|-----------|--|
| | Output - BHP (kW) | 150 (112) | 171 (128) | |
| Ventilation Air Required - CFM (litre/sec) | 252 (119) | 347 (164) | | |
| Exhaust Gas Flow - CFM (litre/sec) | 706 (333) | 882 (416) | | |
| Exhaust Gas Temperature - °F (°C) | 1054 (568) | 1054 (568) | | |
| Heat Rejection to Coolant - BTU/min. (kW) | 3809 (67) | 4209 (74) | | |
| Heat Rejection to Ambient - BTU/min. (kW) | 1345 (24) | 1384 (24) | | |

Engine Performance Curve for CFP59-F40

Torque Output

| RPM | lb-ft | N-m |
|------|-------|-----|
| 1470 | 536 | 727 |
| 1760 | 510 | 692 |

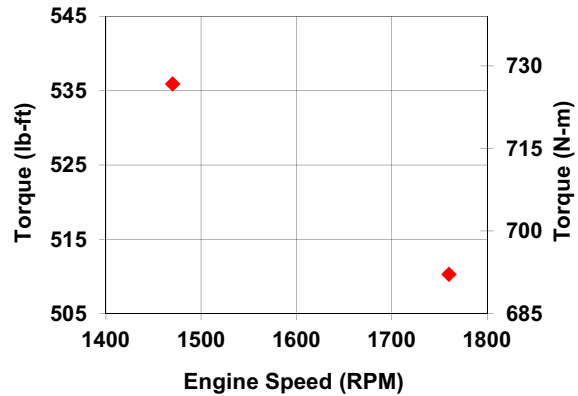

Horsepower Output

| RPM | BHP | kW |
|------|-----|-----|
| 1470 | 150 | 112 |
| 1760 | 171 | 128 |

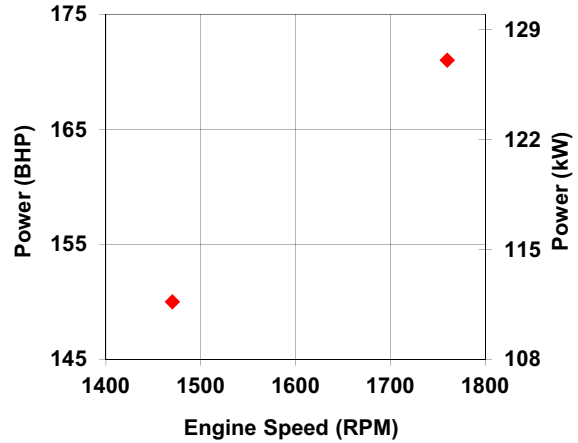

Performance Data

All data is based on the engine operating with a fuel system, water pump, lubricating oil pump, air cleaner, and alternator. The fan, optional equipment, and driven components are not included. Data is based on operation at SAE standard J1394 conditions of 300 ft. (91.4 m) altitude, 29.61 in. (752 mm) Hg dry barometer, and 77 °F (25 °C) intake air temperature, using No.2 diesel fuel only.

| | |
|---|------------------|
| Altitude above which output should be limited*: | 300 ft. (91.4 m) |
| Correction factor per 1000 ft. (305 m) above altitude limit: | 3% |
| Temperature above which output should be limited: | 77 °F (25 °C) |
| Correction factor per 10 °F (5.6 °C) above temperature limit: | 1% (2%) |

* Above 5,000 feet, contact Cummins for derate information.

Fire Pump Digital Panel (FPDP)



The Cummins FPDP is an integrated microprocessor-based control system that provides full digital technology with enhanced accuracy and built-in redundancy.

Reliable design - Designed and tested with isolated mounting to minimize vibration for longer life and durability, the Cummins FPDP proves reliable in harsh environments.

Advanced control methodology - The Cummins FPDP allows for Input/Output (I/O) expansion and remote monitoring capabilities, as well as automatic Electronic Control Module (ECM) switching for electronic engines.

Certified Quality - The Cummins FPDP is UL 1247-listed and FM 1333-approved.

Operator Panel Features

Operator/Display Panel

- 7" TFT LCD (thin-film-transistor liquid-crystal display) - color, 24-bit, 800x480 (WVGA).
- Auto, manual, start, stop, and fault reset.
- Assembly enclosure that meets Type 2 and Type 4X design requirements and is water, corrosion, fire, and impact-resistant.

Electronic Engine Communications - SAE J1939 protocol.

- Comprehensive full-authority engine (FAE) data: oil pressure and temperature; coolant temperature; and intake manifold pressure and temperature.
- Cummins fault code display.
- Sensor failure indication.
- Optional RS-485 serial - Modbus[®] RTU/Modbus[®] TCP/IP.

Variable Speed Pressure Limiting Control (VSPLC) Capabilities

- Display indicates when VSPLC is active.
- Pump discharge pressure display.
- Ability to run the engine at fixed speed from the FPDP at start-up for commissioning.

Other Control Features

- Digital Panel Expansion Module (DPEM) for additional analog/digital inputs and configurable dry relay contact output.
- Ability to idle at start-up for commissioning of electronic engines.
- Idle cool down for electronic engines.
- DC voltage.

Functional

- Configurable display units for temperature in degrees Fahrenheit or Celsius and pressure in PSI or kPa.
- Manual ECM selector switch on electronic engines.
- Ability to crank the fire pump drive engine from Battery A, Battery B, or both.
- Fixed engine speed adjustments in +/- 10 RPM increments.
- Overspeed shutdown.

Environmental

- Operating temperature - 4 to 158 °F (minus 20 to 70 °C).
- Storage temperature - minus 22 to 176 °F (minus 30 to 80 °C).
- Meets CISPR 11 Class B radiated emissions.
- Vibration: 7 G_{PEAK}; three-axis.

Electrical

- 8-30 VDC operating voltage.
- Reverse polarity protected.
- Spring cage terminal block interface.
- Built-in dual micro controllers for increased reliability.

Mechanical

- 1 3/8" pre-cut customer conduit knockout for easy field installation.
- Simplified internal design for efficiency and ease of customer connections.
- 16GA ASTM A366 material - 316 stainless steel optional.
- RAL3001 red powder coat finish.

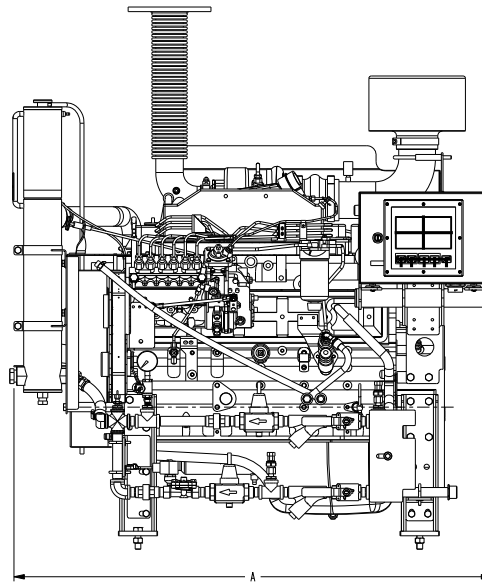
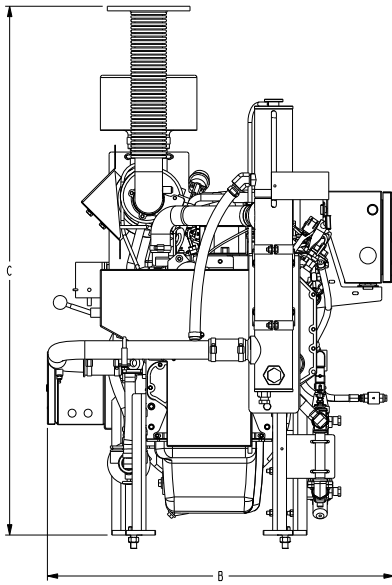

This outline drawing is for reference only.
Do not use for installation design.

| | Dim "A" in. (mm) | Dim "B" in. (mm) | Dim "C" in. (mm) |
|--------------|---------------------|---------------------|---------------------|
| CFP59 | 52 (1320) | 38 (959) | 58 (1462) |

NOTE: Consult drawings or contact the factory for additional information.



This product has been manufactured under the controls established by a Bureau Veritas Certification approved management system that conforms with ISO 9001:2015.

NOTE: Codes or standards compliance may not be available with all model configurations - consult factory for availability. Specifications are subject to change without notice.

For more information, contact firepumpsales@cummins.com.



Cummins Sales and Service
 875 Lawrence Drive
 DePere, Wisconsin 54115
 1 920 337 9750

www.cumminsfirepower.com