



Marine generator set Quiet Diesel™ Series 13.5/17 QD Model MDKDP



Features and benefits

- Rugged dependability, high quality and innovation make Cummins Onan Marine Generators the leader in marine generator design and development, providing Performance you rely on.™
- The digital QD (Quiet Diesel) Series models are the first marine generator sets with self-monitoring capability and network communication.
- The optional Cummins Onan Digital Display provides user-friendly diagnostics including extensive engine and alternator information, self-diagnostic features and text display.
- The Cummins Onan Marine Generators with advanced design and development processes use technology to lower sound and vibration. Our sound shields minimize noise and deliver better sound quality. The optimized mounting system greatly reduces vibration.
- Certified to U.S. Environmental Protection Agency (EPA) emission standards (60 Hz models only).
- Cummins Onan Marine Generators have the largest worldwide certified distributor/dealer support network in the industry with more than 70 years of experience.

Models and ratings

Model	kW/kVA	Voltage	Amps	Phase	Hz	Engine RPM	
13.5MDKDP	13.5/13.5	110/220	122.7/61.4	1	50	1500	
		115/230	117.4/58.7	1	50	1500	
		120/240	112.5/56.3	1	50	1500	
17.0MDKDP	13.5/16.9	220/380	25.6	3	50	1500	
		17.0/17.0	120/240	141.7/70.8	1	60	1800
		17.0/21.2	120/208	59.0	3	60	1800

Other single and three phase configurations are available, contact your distributor/dealer for more information.
Rating conditions are 100 kPa (29.6 in Hg) barometric pressure, 30% relative humidity and 25° C (77° F) (ref. ISO 3046).

Weight and size

	Dimensions			
	Weight (dry) kg (lbs)	Length mm (in)	Width mm (in)	Height mm (in)
With sound shield	408 (899)	1127 (44.4)	602 (23.7)	698 (27.5)
Without sound shield	381 (840)	1127 (44.4)	602 (23.7)	672 (26.5)

Standard features

- Advanced digital electronic control providing extensive diagnostic capability
- Shutdown with diagnostic indicator light for: high engine coolant temperature, high exhaust temperature, low oil pressure, over speed/voltage, starter overcrank, no raw water flow, additional customer input and many more
- Start-run-stop switch with glow plug preheat and fuel pump priming modes for easy starting; run light and diagnostic indicator light
- Start function has automatic glow plug preheat providing better, cleaner starting
- Engine starter with automatic start disconnect
- Electronic governor allows the generator set to maintain isochronous frequency control and close voltage regulation to provide quality power for digital appliances and computers
- Single phase AC alternator with single or dual voltages, brushless
- Digital voltage regulator integral with control
- 12 V DC electric system with battery charging, negative ground
- Electric fuel transfer pump for priming and lift capability
- DC control console mounted with isolation and DC protective circuit breakers
- Freshwater cooling system with heat exchanger, expansion tank and coolant recovery system
- Water cooled exhaust mixing elbow
- Gear-driven raw water pump
- AC mainline circuit breaker
- Running time meter
- Air intake silencer
- Captive focalized mounting systems with vibration isolators
- Full flow lube oil filter
- Oil drain and hose extension
- Electric fuel shut-off via electronic governing actuator
- Fuel filter/water separator
- Drip pan base capable of containing all generator set fluids
- Bulk head type connections for ease of installation include fuel in, fuel out, battery, raw water inlet, wet exhaust, generator set ground (vessel bond)
- Single point lifting bracket for ease of installation
- Plug-in watertight connector for optional remote control
- Closed crankcase breather re-circulation to eliminate engine room contamination
- Coolant overflow bottle to easily maintain coolant level
- Fire extinguisher access port
- Factory load tested
- Five year limited warranty

Engine details

Design: 4-cycle, water-cooled diesel

Cylinders: 4

Bore: 83 mm (3.27 in)

Stroke: 92.4 mm (3.64 in)

Displacement: 1999 cm³ (122 in³) 50 Hz; 2434 cm³ (148.5 in³) 60 Hz

Compression ratio: 22.8:1

Max fuel lift: 1.22 m (4 ft)

Lube oil capacity: 7.6 L (8 qt)

Coolant capacity: 7.6 L (8 qt)

Coolant flow rate: 50 Hz: 37.9 L/min (10.0 Gal/min); 60 Hz: 53.0 L/min (14.0 Gal/min)

Raw water flow rate: 50 Hz: 26.5 L/min (7.0 Gal/min); 60 Hz: 34.1 L/min (9.0 Gal/min)

Starting system: Remote 3-wire, 12 V starting battery required, 95 Ah, 625 CCA; 24 V optional

Power (max): SAEJ1995

50 Hz at 1500 RPM 19.9 kW (26.7 hp)

60 Hz at 1800 RPM 27.6 kW (37.0 hp)

Fuel injection pump: Bosch PFR-M mini

Combustion Chamber: Spherical, three vortex combustion system

Max Raw Water Lift: 1.22 m (4 ft)

Typical fuel consumption

No. 2 diesel fuel, L/hr (Gal/hr)	No load	1/4 load	1/2 load	3/4 load	Full load
13.5 MDKDP-50 Hz	1.1 (0.3)	1.9 (0.5)	2.7 (0.7)	3.6 (0.9)	4.8 (1.3)
17.0 MDKDP-60 Hz	1.8 (0.5)	2.6 (0.7)	3.6 (1.0)	4.8 (1.3)	6.1 (1.6)

Alternator details

Design: Cummins Onan brushless, revolving field, 4-pole alternator, rigidly coupled to engine and permanently aligned

Voltage Regulator: Solid state, circuit board encapsulated for corrosion protection

Exciter system: Brushless with 8-pole stator mounted in endbell; rotating rectifier assemblies are encapsulated for protection from adverse environments

Stator: Skewed stator and 2/3 pitch windings minimize field heating and voltage harmonics; resin-coated for corrosion protection

Rotor: Dynamically balanced assembly; direct-coupled to engine by flexible drive discs; supported by pre-lubricated, maintenance-free ball bearings

Cooling: Direct drive centrifugal blower

Insulation system: Class H per NEMA MG1-1 -1.65 and BS 5000

Generator set performance

Operating environment: Generator sets are durability tested at maximum ambient air temperature: 50° C (122° F) and raw water temperature: 37.8° C (100° F)

Frequency regulation: Isochronous

Random frequency variation: Will not exceed +/-0.5% of its mean value for constant loads from no load to full load

Voltage regulation: No load to rated load +/-1%

Random voltage variation: Will not exceed +/-0.5% of its mean value for constant loads from no load to full load

Performance you rely on.™

©2014 Cummins Power Generation Inc. | NAS-5897a-EN (2/14)

power.cummins.com

Basic dimensions

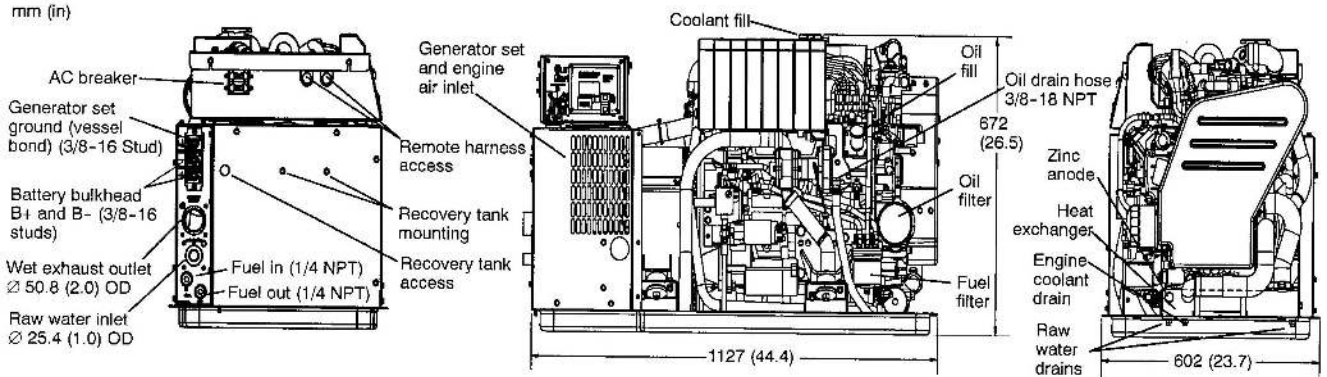

Note: This outline drawing is provided for general reference only and is not intended for design or installation. For more information see Operation and Installation manuals or obtain drawing 500-4944 and wiring diagram from your distributor/dealer.

Options

- Cummins Onan Digital Display - graphical LCD set-mounted display for generator set operating parameters, diagnostics, and pre-alarm indication in text format
- NMEA2000, SAE J-1939 and SmartCraft 1.0 data links available for monitoring generator.
- Low coolant level shutdown
- Keel cooling with wet exhaust
- Keel cooling with dry exhaust
- 12 V DC electric system with battery charging, isolated DC
- 3 phase, 125 °C broad range alternator with a variety of voltages
- 24 V DC electric system with battery charging, negative ground or isolated DC
- Dry exhaust system (up or down orientation)
- Sound shield housing
- Front power take-off (PTO) for full engine output with clutch, flexible coupling and SAE B flange pump mounting for a 2 and 4 bolt mounting (12 or 24 V DC clutch)
- Engine end interface connection
- Engine end wet exhaust outlet
- Remote shutdown harness for fire extinguisher connection



Standard model without sound shield shown

Accessories

- Cummins Onan Digital Display - graphical LCD remote display for generator sets operating parameters, diagnostics, and pre-alarm indication in text format
- Basic remote panel with start/stop switch with run (green) and control status (amber) lamps
- Remote start/stop switch with dual lamps and mating harness only for panel installation
- 12 or 24 volt isolated ground conversion kit, no battery charging
- Y adapter harness for dual remote stations
- Remote station harness pigtail
- Remote panel wire harness - 15 ft, 25 ft, 45 ft, 75 ft, 100 ft or 150 ft
- Line circuit breakers for field conversion of frequency or AC voltage output
- Remote fuel filter/water separator assembly
- Fuel supply and return hose barb connectors
- Dry exhaust muffler, flexible exhaust stainless steel tube assembly
- Siphon break kit
- Wet exhaust hose and stainless steel elbow
- Battery
- Bulk head battery terminal boots
- Low coolant level shut down switch
- Front or rear exhaust outlet kit
- Dry exhaust fitting
- Marine mufflers, water separator, and resonator dual silencers
- Front power take-off (PTO) for full engine output with clutch, flexible coupling and SAE B flange pump mounting for 2 and 4 bolt mounting (12 or 24 VDC clutch); additional sound shield front panel or belt guard is required
- Sound shield housing
- Cruise kit - maintenance parts - fuel filters, oil filters, raw water pump impellers, zinc pencils, alternator belt and plastic container
- Keel cooling conversion for wet or dry exhaust



Cummins Onan Digital Display



Cummins Onan Cruise Kit

Standards and testing

National Marine Manufacturers Association (NMMA) members produce every conceivable product used by recreational boaters. NMMA provides a wide variety of programs and services including technical expertise, standards monitoring, government relations advocacy and industry statistics.

The American Boat and Yacht Council (ABYC) develops standards and recommended practices for designing, constructing, equipping and maintaining small pleasure and commercial craft.

This generator set was designed and manufactured in facilities certified to ISO 9001.

Lloyd's Register states that Cummins Onan Marine Generators have been successfully tested in accordance with the relevant requirements of the Lloyd's Register Type Approval System for Marine, offshore and industrial applications.



Warranty policy

The Cummins Onan express, written limited warranty covers virtually everything except routine maintenance for the first two years you own your marine generator set, and covers parts and labor on major power train and generator set parts during the third through fifth years.

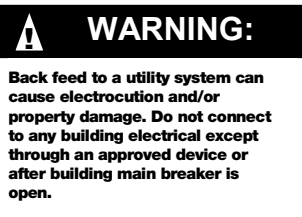

After sale support

Largest distributor/dealer support network

Cummins Onan generator sets are supported by the largest and best trained worldwide certified distributor/dealer network in the industry. This network of knowledgeable Cummins Onan distributor/dealers will help you select and install the right generator set and accessories to meet the requirements of your specific application. This same network offers a complete selection of commonly used generator set maintenance parts, accessories and products plus manuals and specification sheets. Plus, they can answer your questions regarding proper operation, maintenance schedules and more.

Manuals: Operation, installation and parts manuals ship with the generator set. To obtain additional copies or other manuals for this model, see your Cummins Onan distributor/dealer and request the following manual numbers: Installation (A046J598), Operation (A046J600), Service (A046J602), Parts (A046L892).

To easily locate the nearest Cummins Onan distributor/dealer in your area, or for more information, contact us at 1-800-888-6626 (or 763-574-5000), or visit www.cumminsonan.com.

Contact your distributor/dealer for more information.

Cummins Onan

Cummins Power Generation

1400 73rd Ave. NE
Minneapolis, MN 55432 USA
Phone 1 763 574 5000
Toll-free 1 800 888 6626
Fax 1 763 574 5298
Email ask.powergen@cummins.com

Performance you rely on.™

©2014 Cummins Power Generation Inc. All rights reserved.

Cummins®, Onan®, the "C" logo, Performance you rely on.™ and Quiet Diesel™ are servicemarks, trademarks and/or registered trademarks of Cummins Inc. Other company, product, or service names may be trademarks or service marks of others.

Specifications are subject to change without notice.

NAS-5897a-EN (2/14)



power.cummins.com