

POWERING BUSES IN A WORLD THAT'S ALWAYS ON.

B4.5 & B6.7 EURO VI ENGINES



ALWAYS ON

SETTING THE INDUSTRY STANDARD

The four-cylinder B4.5 and six-cylinder B6.7 have earned an unrivalled position as the world's leading engine platform for city bus applications, ranging all the way from midi-bus to double-deck and intercity buses, as well as coaches and hybrids. Indeed, no other engines power more buses, in more cities, and in more countries worldwide than the Cummins B Series.

And that's because no other engine can offer such high levels of performance and in-service reliability whilst operating under the most challenging duty-cycles. The ability to keep delivering under long service hours, very high annual mileages and challenging route terrain comes as standard with the Cummins 4.5-litre and 6.7-litre B Series.

PERFORMANCE ENHANCED

The latest Euro VI B4.5 and B6.7 come packed with performance enhancing technology to realise the full potential of the high strength, proven base engine platform. Cummins Variable Geometry Turbocharger (VGT™) enables high torque from lower engine speeds to improve driveability while accelerating. A state-of-the-art fuel system continually adjusts injection pressures to minimise fuel consumption, particularly during slow speed with high passenger loadings.

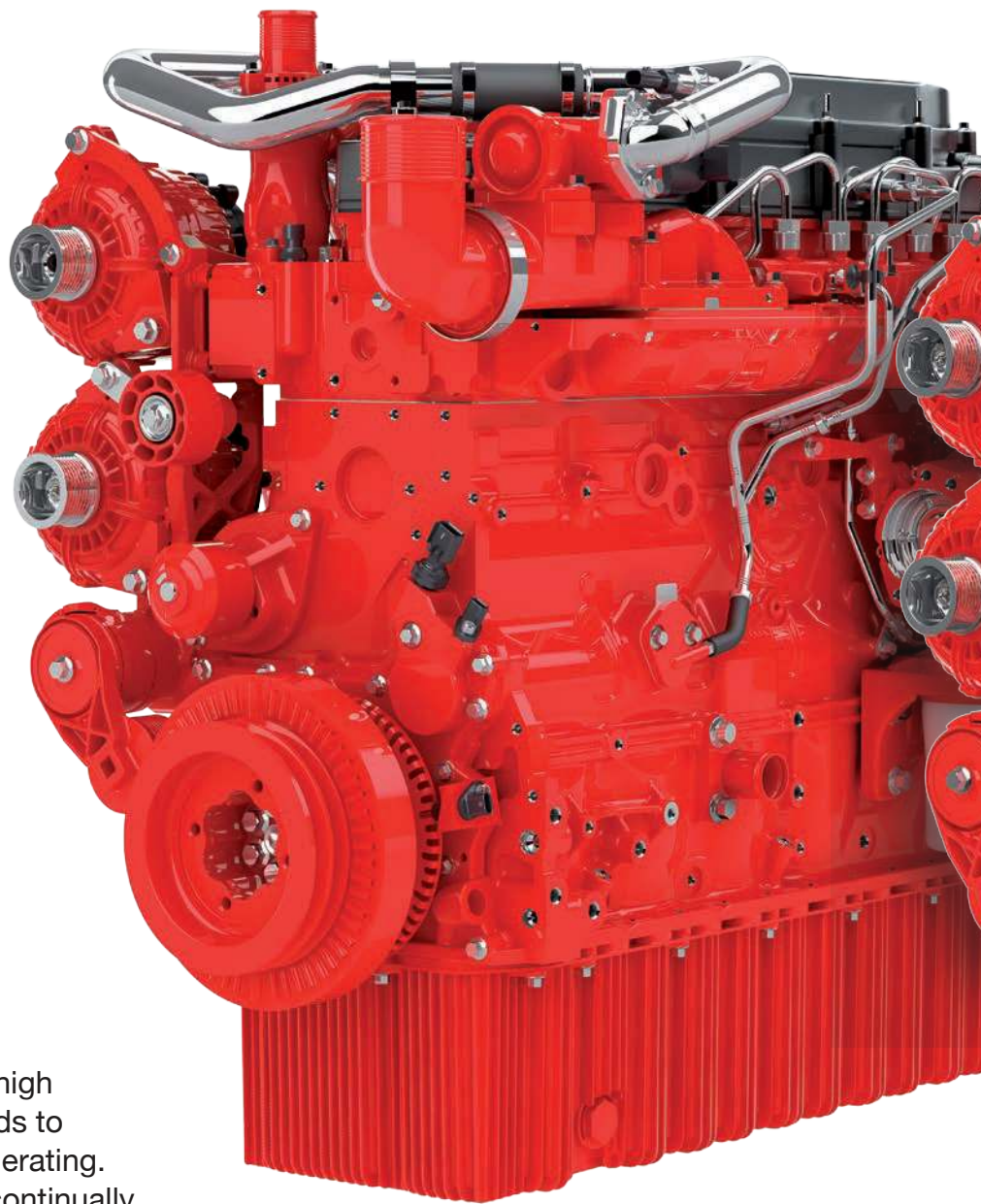

B6.7™

SMART EFFICIENCY

Due to a more compact envelope with the highest power density in their class, the B4.5 and B6.7 bring a significant installation advantage, together with an engine management system that seamlessly integrates into the vehicle controls. Smarter electronics also means that engine diagnostics and trip data can be quickly accessed with Cummins digital service tools, and instantly converted into easy-to-read analytics to enable proactive maintenance when its needed.

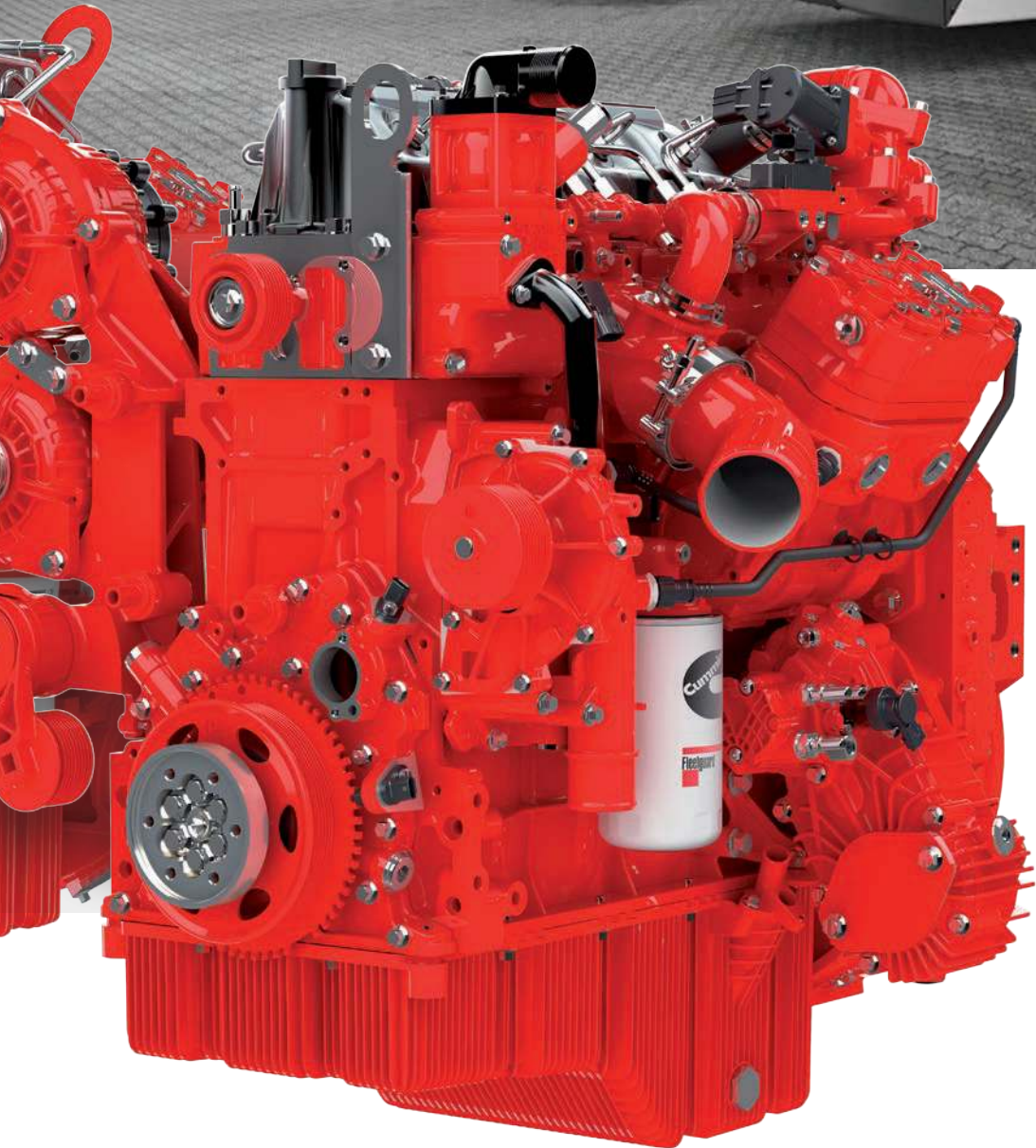

B4.5

STOP-START TECHNOLOGY

The B4.5 and B6.7 Euro VI bus engines can incorporate Cummins' unique Stop/Start technology, with the capability to eliminate almost all engine idling at bus stops, traffic lights and pedestrian crossings. The engine-off mode can automatically operate for up to 30 stops per hour, dependent on the route. The engine position sensor ensures instant readiness for a soft restart in just 0.5 seconds following the engine-off mode.

The Stop/Start function can achieve up to 8 percent fuel savings on city bus duty cycles, potentially saving over 2,000 litres of fuel annually, with a corresponding greenhouse gas saving of around 5 metric tons of CO₂ per year. Stop/Start technology is helping to enhance bus sociability around cities for both passengers and pedestrians.

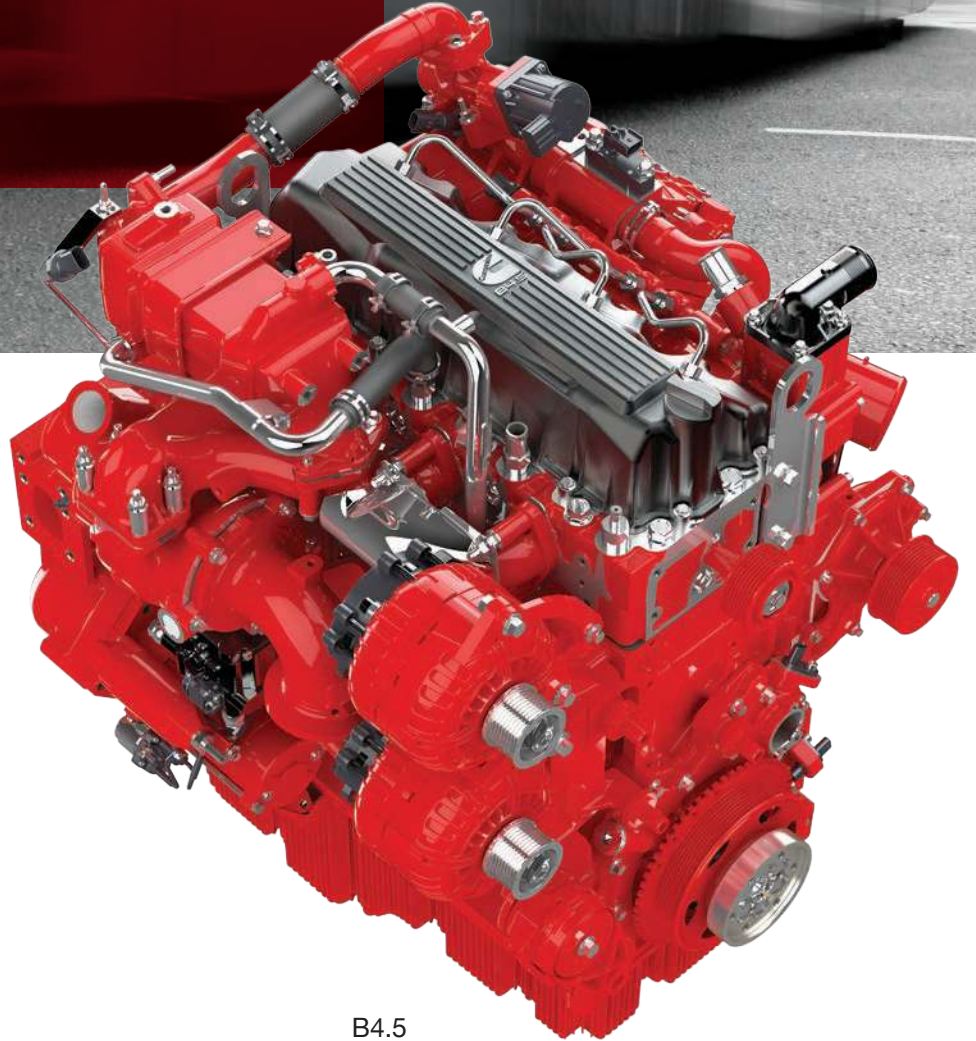
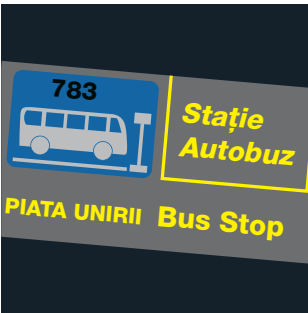

B4.5

ROBUST DESIGN

While the B Series achieves the longest life to overhaul of any comparable engines, Cummins goes even further by designing-in ease of overhaul.

As a result, operators can maximise their investment in keeping buses on the road for longer with engine overhaul programs.

Scheduled engine service requirements are few and far between, meaning that a bus fleet goal of over 95 percent uptime availability is fully achievable with the B Series.

And, you can be sure, wherever there is a Cummins-powered bus, there is a Cummins service team ready to provide expert technical support. From inspecting engine systems on new buses before they enter service, training-up depot staff or working with operators to minimise fuel consumption, this is all part of Cummins' commitment to support our customers.

Always On.

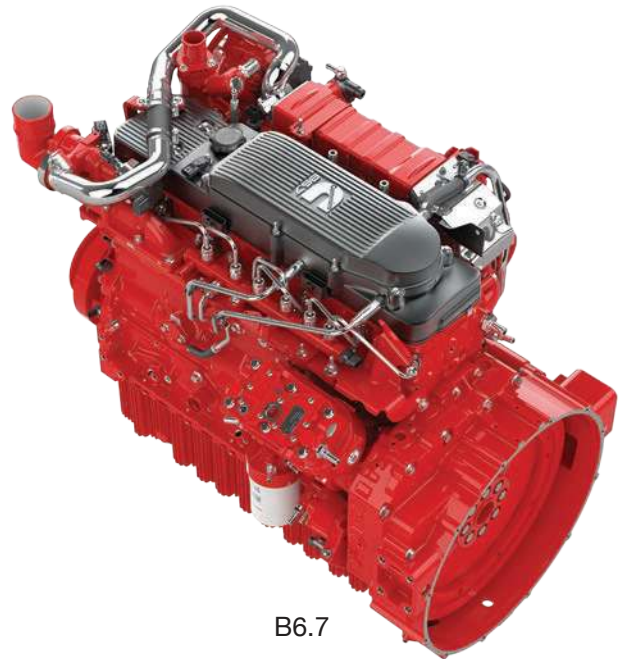

B6.7

HYBRID-ADAPTED

Cummins has achieved a Euro VI technology milestone by reaching a total of over 2,000 hybrid-adapted engine installations in buses operating across Europe, making a major contribution to improving air quality and reducing the carbon footprint. Cummins 'H' versions of the B4.5 and B6.7 are specially configured to integrate with the hybrid driveline and provide a seamless engine on/engine off function for the vehicle.

Cummins' hybrid engine expertise has played a key role in helping many bus manufacturers on the road to electrification and has achieved remarkable results in terms of fuel savings, emissions reduction and vehicle sociability. On-road testing with Cummins engines on city bus duty cycles has indicated that nitrogen oxide (NOx) emissions are capable of being reduced to 50 percent below the Euro VI standard. In terms of fleet decarbonisation, we typically see hybrid drive buses reducing fuel consumption and related CO₂ emissions by around 33 percent, with the engine contributing an important part of that reduction.

Cummins hybrid engines are fully optimised to be used within all hybrid drivelines, including those supplied by Siemens, BAE Systems, Eaton and Allison. They are compatible with both series or parallel hybrid systems, as engine parameters are adjusted to lower or higher average speed duty cycles. The hybrid engine is streamlined by eliminating power-take-off accessories used to drive steering pumps, fan drives, air compressors and air-conditioning as they can be run directly from the electrical supply from the battery. The starter motor can also be removed, although this is retained in some buses as a back-up.

With Cummins engines specifically developed to enhance hybrid system performance, this capability provides operators with the energy choice they need alongside conventional clean diesel drivelines, the option of renewable natural gas power, full-electric and fuel cell solutions from Cummins.

COACH POWER

The same attributes that have established the B6.7 as the leading mid-range engine for city buses have proved equally applicable to the growing market for midi-sized coaches, with less than 11 metre length and with up to 40 seats capacity. The exceptional power density of the 6.7-litre makes it the engine of choice for this highly versatile class of coach, used for roles including day touring, intercity services, luxury shuttle duties or premium long distance touring.

When powered by the B6.7 there is no compromise on performance. Specific coach engine ratings release the full potential of the B6.7 up to 320 hp to provide rapid acceleration and high cruising speeds. But what really sets the Cummins-powered midi-coach apart from full size coaches is the remarkably lower fuel

consumption – enabling a major cost saving for operators.

Fuel and CO₂ reductions are even more impressive with a new generation of coaches of up to 13 metre length utilising Cummins B6.7 hybrid engine. This design meets the need for shorter distance commuter, suburban or school transport operating through low emission zones.

For smaller coaches sized below 8.5m length and with around 30 seat capacity, the compact B4.5 is an ideal power source with up to 210 hp output. While the B4.5 brings the operational cost saving of a high efficiency 4-cylinder engine, out on the road it provides the smooth acceleration and relaxed cruising speed associated with the larger B6.7.

B6.7

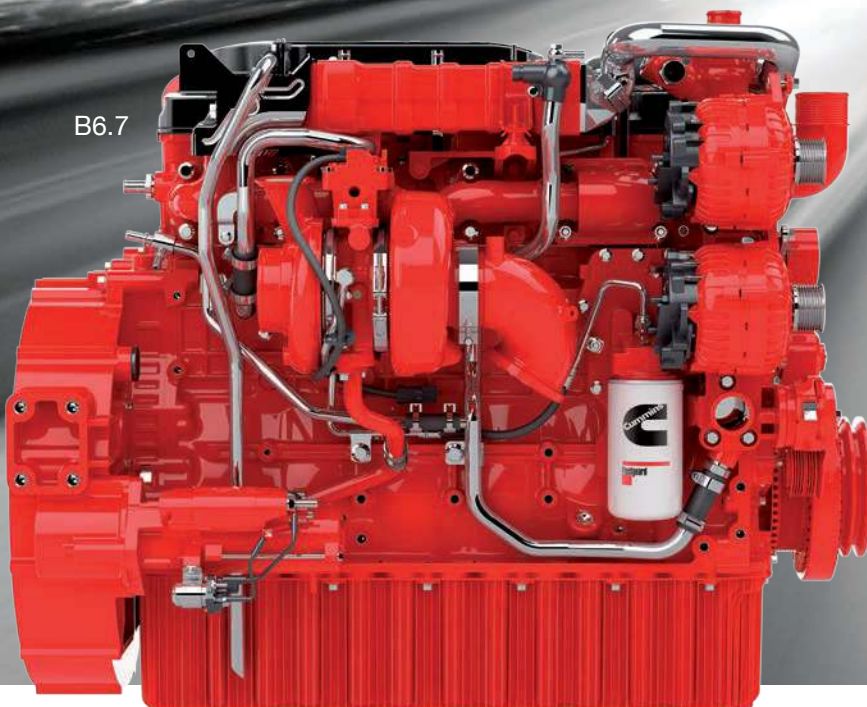

B4.5

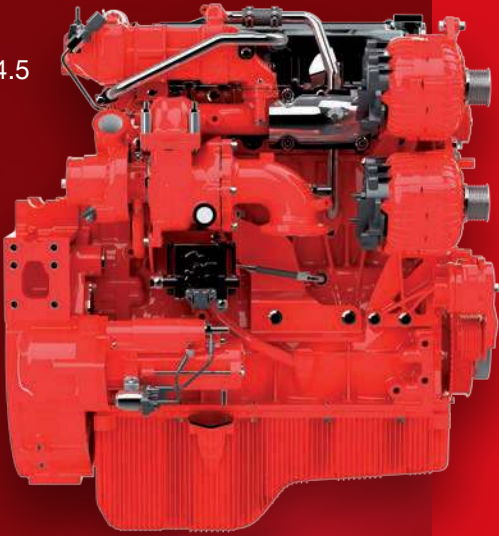

STEP AHEAD TO PHASE-D

The 2019 Euro VI Phase-D regulatory step is particularly relevant for bus operations, as it is focused on tighter control limits for NOx emissions during lower speed city operations and under cold start conditions. Certification is dependent on test results taken during real-world drive cycles, verifying results first taken under engine emissions test cell conditions.

On-road testing with Cummins Phase-D engines during typical city bus duty cycles have indicated a further 25 percent reduction in Nitrogen Oxides (NOx) compared to the initial Phase-A engines when Euro VI was first introduced in 2015.

This nearer-to-zero reduction has been verified with the use of high precision Portable Emissions Measurement Systems (PEMS) installed on the Cummins-powered test vehicles.



LOWERING THE CARBON FOOTPRINT

Beyond the substantial fuel saving benefits offered by the latest B4.5 and B6.7 engines, an even lower carbon footprint can be achieved when running on B20 biodiesel or HVO renewable fuel. Compared with conventional fossil-based fuel, HVO (Hydrotreated Vegetable Oil) offers the potential to reduce greenhouse gas (GHG) emissions by 40 to 90 percent, depending on the feedstock of the fuel.



ENGINE RANGE SPECIFICATIONS

BUS RATINGS



B4.5	150 hp @ 2300 rpm (112 kW)	650 Nm @ 1000 rpm
	180 hp @ 2300 rpm (134 kW)	700 Nm @ 1000 rpm
	210 hp @ 2300 rpm (157 kW)	850 Nm @ 1200 rpm
B6.7	220 hp @ 2100 rpm (164 kW)	900 Nm @ 1000 rpm
	250 hp @ 2100 rpm (187 kW)	1000 Nm @ 1000 rpm
	280 hp @ 2100 rpm (209 kW)	1100 Nm @ 1000 rpm
	300 hp @ 2100 rpm (224 kW)	1200 Nm @ 1100 rpm

HYBRID RATINGS

B4.5-H	180 hp @ 2300 rpm (134 kW)	700 Nm @ 1000 rpm
	210 hp @ 2300 rpm (157 kW)	850 Nm @ 1200 rpm
B6.7-H	280 hp @ 2100 rpm (209 kW)	1100 Nm @ 1000 rpm
	300 hp @ 2100 rpm (224 kW)	1200 Nm @ 1100 rpm

COACH RATINGS

B4.5	180 hp @ 2300 rpm (134 kW)	750 Nm @ 1100 rpm
	210 hp @ 2300 rpm (157 kW)	850 Nm @ 1200 rpm
B6.7	290 hp @ 2300 rpm (217 kW)	1100 Nm @ 1000 rpm
	320 hp @ 2300 rpm (239 kW)	1200 Nm @ 1100 rpm

	B4.5		B6.7	
Displacement	4.5-litre		6.7-litre	
Architecture	4-cyl. with EGR / VGT		6-cyl. with EGR / VGT	
Ratings Range	112-157 kW / 150-210 hp		164-239 kW / 220-320 hp	
Peak Torque	850 Nm @ 1200 rpm		1200 Nm @ 1100 rpm	
Dry Weight	372 kg		522 kg	
Size L x W x H	809 x 738 x 875 mm		1097 x 788 x 921 mm	
Oil drain interval	Up to 2000 hours Up to 50,000 km (city bus) or 80,000 km (intercity/coach)			

Note: oil drain intervals are dependent on application / duty cycle, based on using CK-4 API (CES 20086 approved) oil specification.

EXHAUST AFTERTREATMENT

Architecture	DPF-SCR switchback unit
Weight	84 kg
Size L x W x H	847 x 610 x 464 mm

The Diesel Particulate Filter and Selective Catalytic Reduction (DPF-SCR) exhaust aftertreatment was purpose-designed by Cummins to work with the engine as an integrated emissions control system. The DPF-SCR combines with in-cylinder combustion and the exhaust gas recirculation system to lower PM and NO_x, certified to the 2019 Phase-D requirement of the Euro VI regulations.

B4.5 Peak Torque

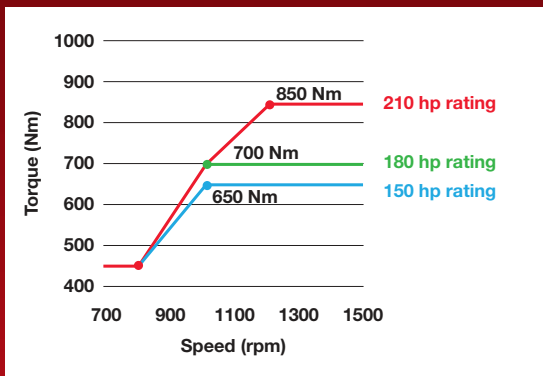

B6.7 Peak Torque

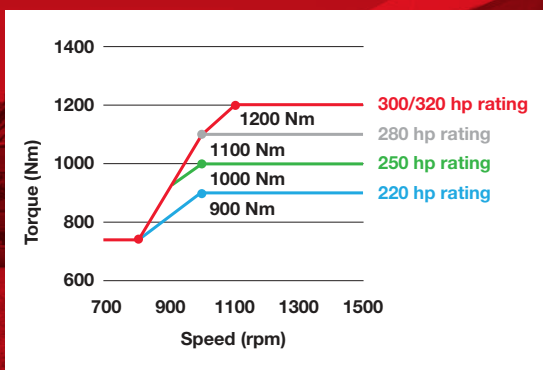

The B4.5 and B6.7 rapidly deliver high levels of torque from low engine speed to enhance vehicle driveability.

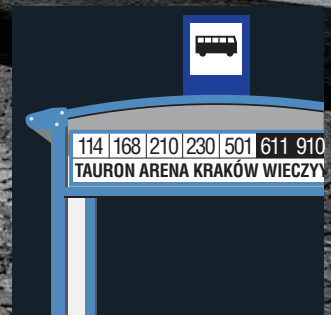

DIGITAL DIAGNOSTICS

Cummins INSITE™ performs engine diagnostics and displays electronic engine information on your PC. With step-by-step diagnostics, built-in engine drawings and schematic diagrams, working with INSITE™ is easy. Using this software speeds up troubleshooting procedures, helping to minimise down time and ensures your bus can quickly be back on the road again.

FEATURES:

- Quick access to trip information
- Adjust parameters and review/clear fault information quickly and easily
- Easy-to-follow troubleshooting assistance
- Wiring and sensor location diagrams
- Store engine and trip information for future use, or as a programming template

Using telematics, you can wirelessly connect your engine for continuous monitoring and diagnosis of system fault alerts using a convenient Cummins mobile app, email or web portal. Products such as Connected Diagnostics and Connected Advisor can play a major role in maximising the uptime availability of your fleet by setting up a diagnostic health report, delivered automatically. This enables preventative maintenance to be scheduled, knowing what needs immediate action and what can wait until the next service inspection.



B4.5



 Connected Solutions™

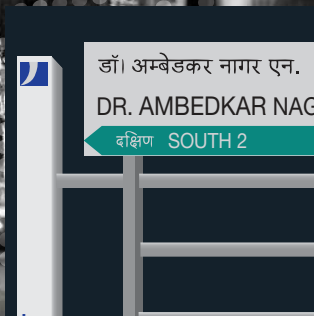
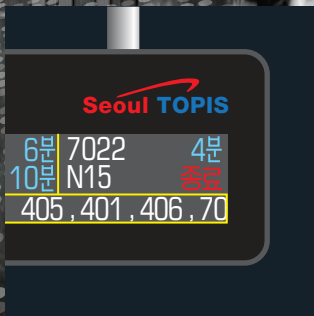

Cummins B series platform is used by bus manufacturers worldwide to meet all Euro equivalent standards and in North America is by far the highest volume bus engine of its class meeting EPA regulations.

B Series global credentials are further enhanced with manufacturing facilities located in six countries.



**POWERING
A WORLD
THAT'S
ALWAYS ON
THE MOVE.**



ALWAYS ON™
cummins.com

All rights reserved. Cummins is a
registered trademark of Cummins Inc.

Bulletin 5600346 Rev. 1/20
©2020 Cummins Inc.