

INDUSTRIAL DIESEL ENGINE

Kubota EA series (1-Cylinder)

EA330-E4



Rated Power

5.15 kW @ 3000 rpm



Photograph may show non-standard equipment.

Performance Curves

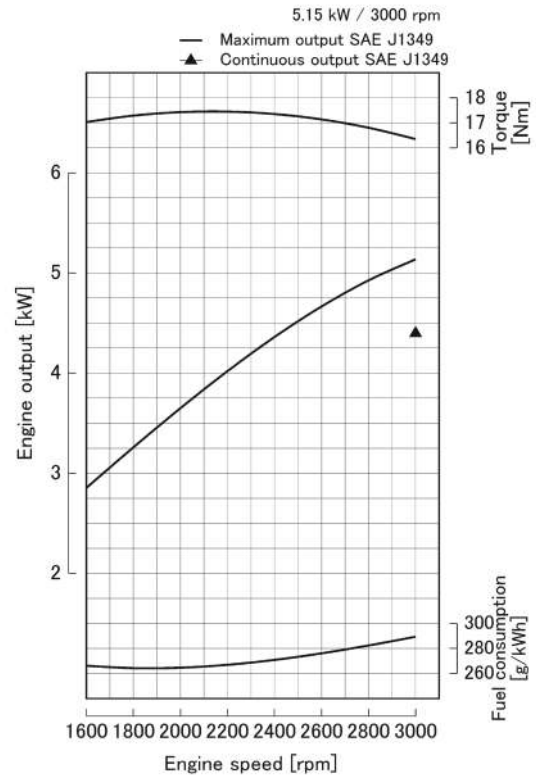

Features and Benefits

Emissions

The Kubota EA330 engine complies with EPA Tier 4 emissions regulations. These are the most stringent emissions regulations in the world in this class. Kubota engine less than 19 kW also meets emission standards over the NRTC and the NTE requirements.

Durable Power

The Kubota EA330 engine has been chosen as the power source for a variety of applications.

Combustion chamber with TVCS (Three Vortex Combustion System) provides stable performance even at high engine rpm. With the extra displacement for its output, work goes surely and steadily. This engine offers a seamless transition from E2 to E4 by entirely maintaining the same performance and physical characteristics.

Clean and Quiet Power

Kubota's original TVCS (Three Vortex Combustion System) provides ideal mixture of air and fuel, and enables low fuel consumption.

For Earth, For Life
Kubota

EA330-E4

Engine Specifications

Engine model	EA330-E4	
Emission regulation	EPA/CARB Tier 4 (NRTC/NTE test mode) + EU Stage V	
Type	Vertical, water cooled 4-cycle diesel engine	
Cylinders	1	
Bore and stroke	mm (in)	77.0 x 70.0 (3.03 x 2.76)
Displacement	L (cu.in)	0.325 (19.8)
Maximum output / speed *1	kW (HP) / rpm	5.15 (6.91) / 3000
Continuous output / speed *1	kW (HP) / rpm	4.4 (5.9) / 3000
Maximum torque / speed	Nm (lb-ft) / rpm	17.65 (13.02) / 2000
Combustion system	Indirect Injection *2	
Fuel tank capacity	L (U.S.gal)	4.8 (1.3)
Lubricating oil capacity	L (U.S.gal)	1.3 (0.34)
Starter capacity	V-kW	12-1.1
Charging dynamo	V-W	12-60
Length x Width x Height	mm (in)	312 x 566 x 457 (12.3 x 22.3 x 18.0)
Dry weight *2	kg (lbs)	54 (120)

Specification is subject to change without notice.
 Dry weight is according to Kubota's standard specification.
 When specification varies, the weight will vary accordingly.

*1: SAE J1349 net intermittent
 *2: Three Vortex Combustion System (TVCS)

Dimensions

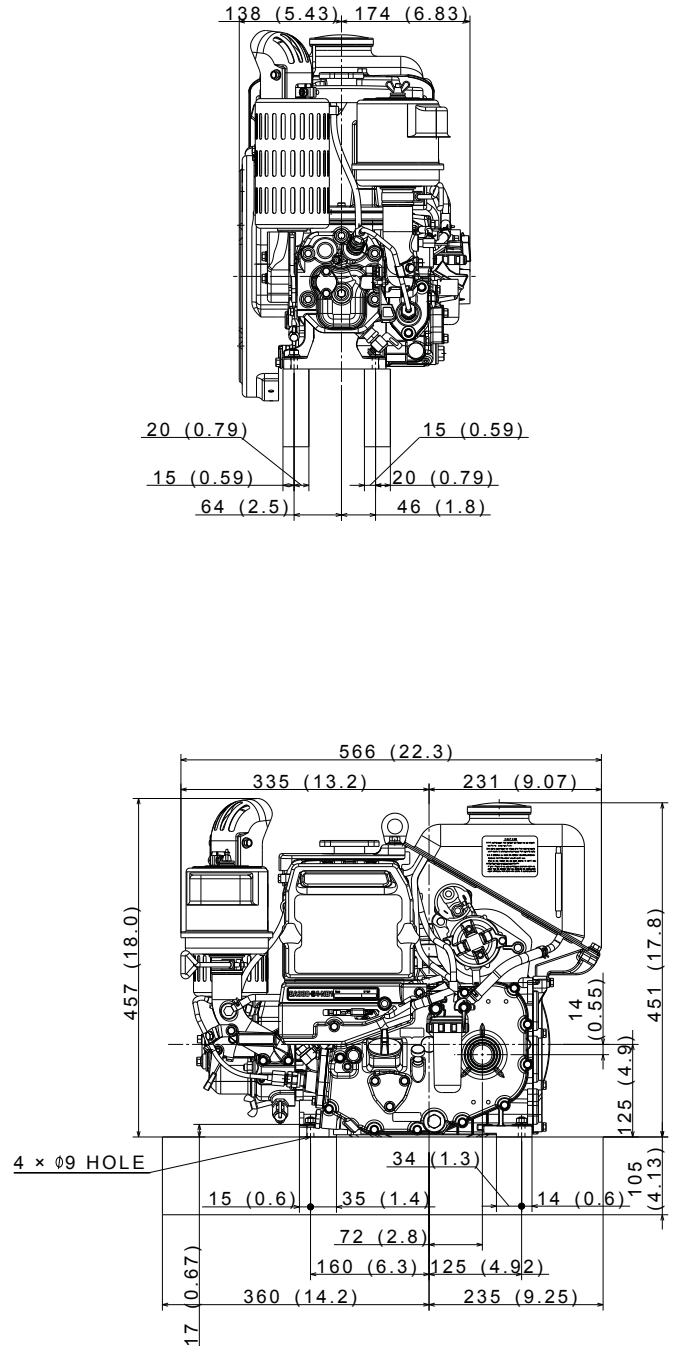

Kubota Corporation

2-47, Shikitsuhigashi 1-chome Naniwa-ku, Osaka, 556-8601 Japan
<https://global.engine.kubota.co.jp/en/>

ASPEA330-E41902-R1-I-178040

