

INDUSTRIAL DIESEL ENGINE

Kubota 05 Series (4-Cylinder)

V1505-E4B



Rated Power

18.5 kW @ 2300 rpm

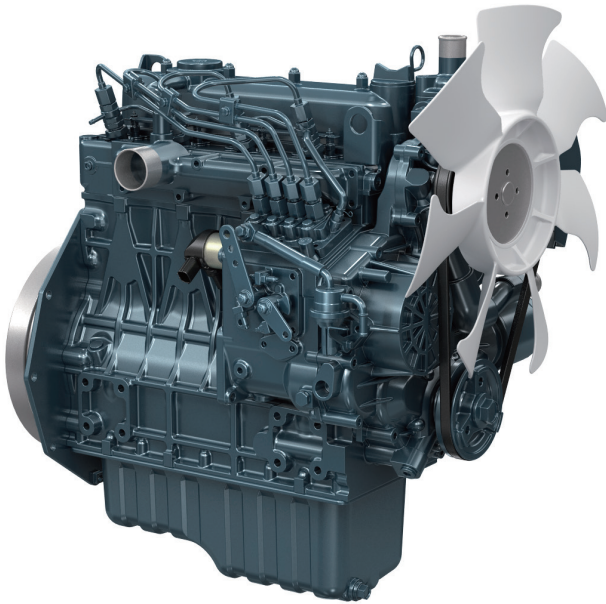

Photograph may show non-standard equipment.

Performance Curves

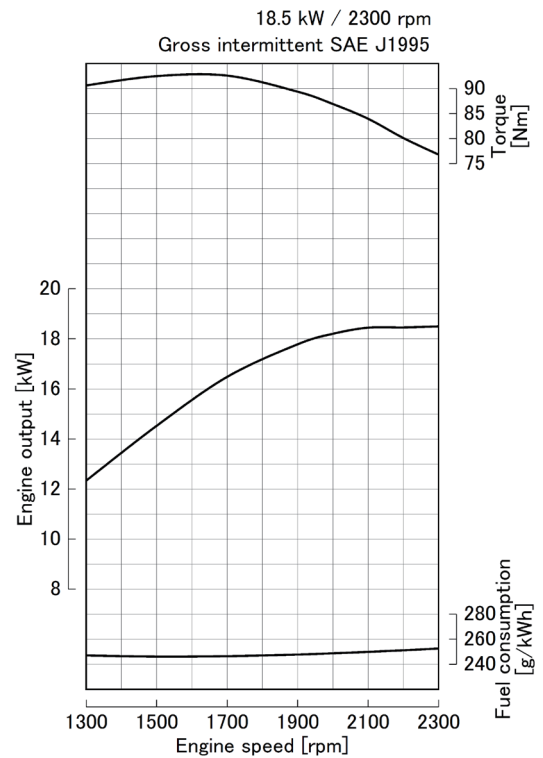

Features and Benefits

Emissions

The V1505 engine complies with EPA / CARB Tier 4 emissions regulations.

Durable Power

The Kubota 05 Series is an established leader, selected as the power source of choice by various industrial equipment manufacturers.

By reducing output, the V1505 engine realizes a smooth transition from E3 to E4.

Clean and Quiet Power

Kubota's original E-TVCS (Three Vortex Combustion System) has been improved. The airflow, combustion chamber, and piston recess have been optimized to provide low particulate matter (PM) levels, matching the stringent level of the emission regulation below 37 kW. The half-float valve cover and MoS₂-coated pistons reduce noise levels and decrease vibrations transmitted from the valve area.

For Earth, For Life
Kubota

V1505-E4B

Engine Specifications

Engine model		V1505-E4B
Emission regulation		EPA/CARB Tier 4 (NRTC/NTE test mode) + EU Stage V
Type		Vertical, water cooled 4-cycle diesel engine
Cylinders		4
Bore and stroke	mm (in)	78.0 x 78.4 (3.07 x 3.09)
Displacement	L (cu.in)	1.498 (91.41)
Aspiration		Naturally aspirated
Aftertreatment		-
Rated output / speed *1	kW (HP) / rpm	18.5 (24.8) / 2300
Maximum torque / speed *1	Nm (lb-ft) / rpm	92.6 (68.3) / 1700
Combustion system		Indirect injection
Fuel system		In-line pump
Length x Width x Height *2 (without aftertreatment unit)	mm (in)	565 x 396 x 607 (22.2 x 15.6 x 23.9)
Length x Width x Height *3 (with aftertreatment unit)	mm (in)	-
Dry weight *3	kg (lbs)	110 (243)

Specifications are subject to change without notice.
Dimensions and dry weight are according to Kubota's standard specification.
Dimensions and weight depend on completed specifications.

*1: SAE J1995 gross intermittent

*2: Exclude cooling fan and exclude aftertreatment unit

*3: Exclude cooling fan and include aftertreatment unit on engine

Dimensions

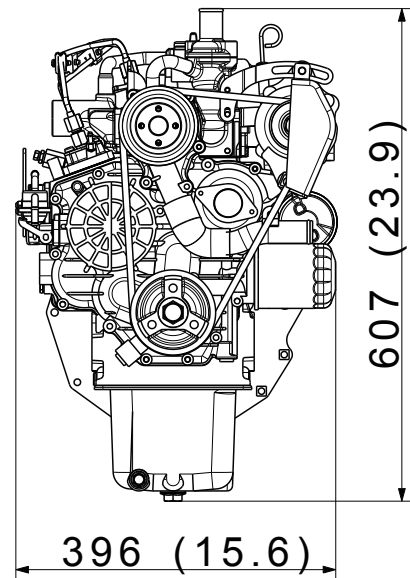
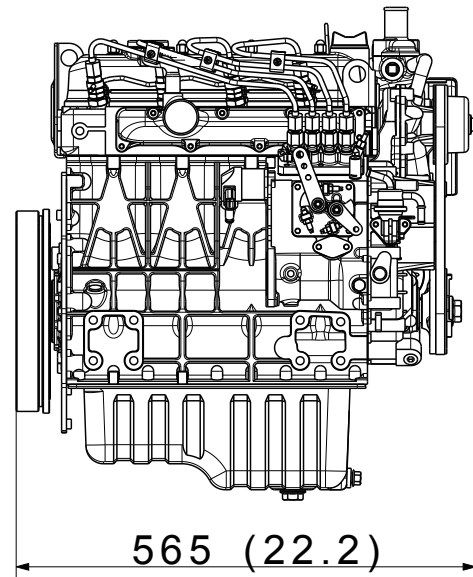

Kubota Corporation

2-47, Shikitsuhigashi 1-chome Naniwa-ku, Osaka, 556-8601 Japan

<https://global.engine.kubota.co.jp/en/>

ASPV1505-E4B1902-R1-I-178040