

QUEEN

50Hz G80IS-M5

VERSION	A	B
150L BOUNDED TANK	1900	300
270L BOUNDED TANK	1900	300

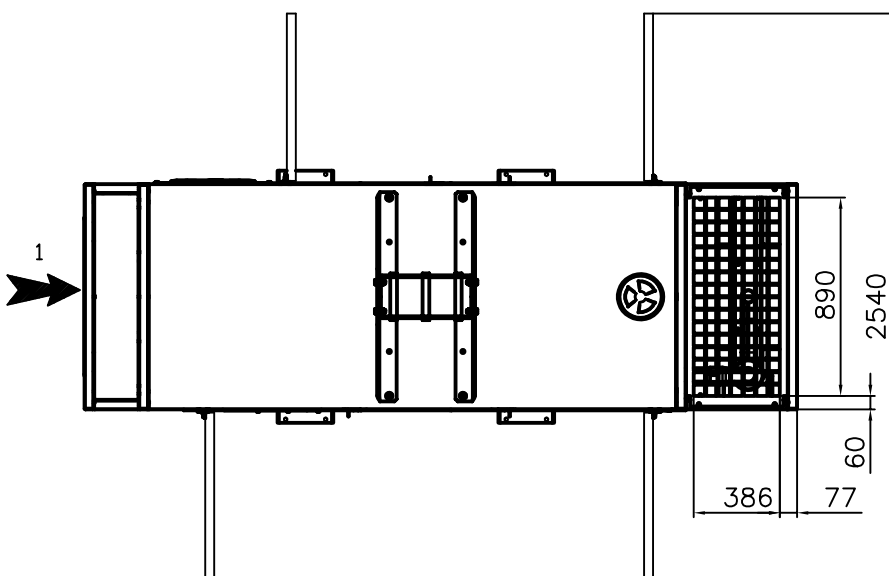
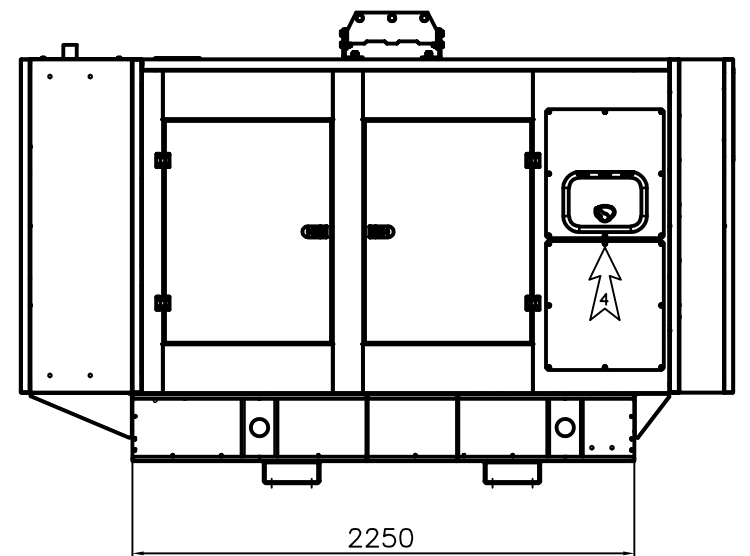
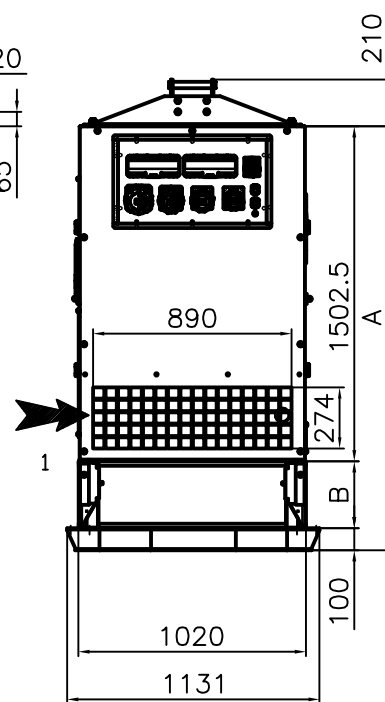
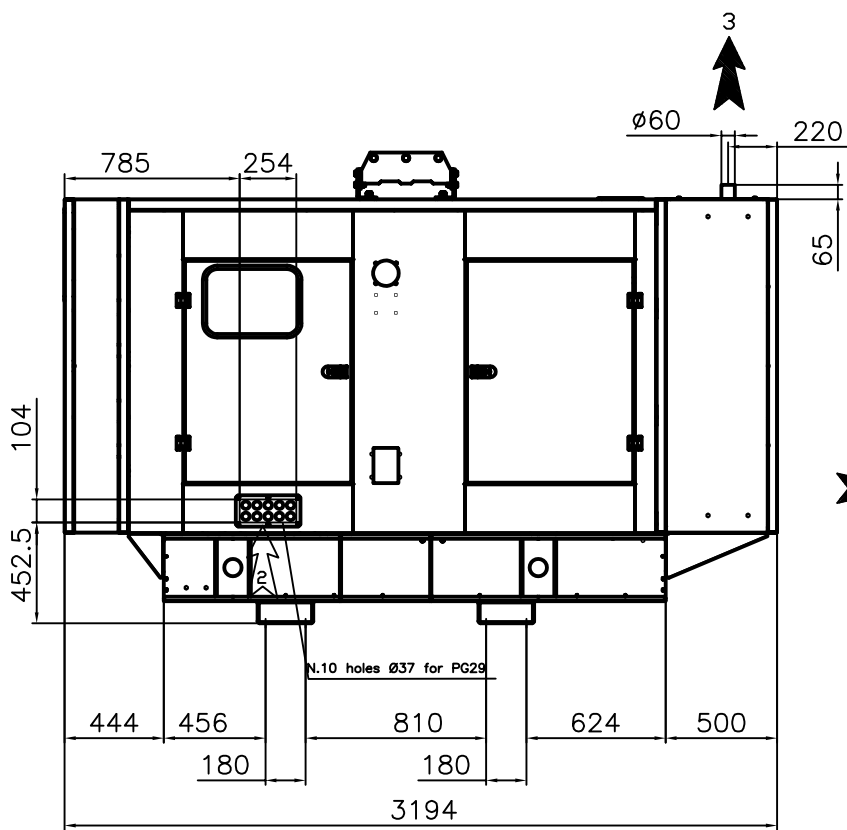
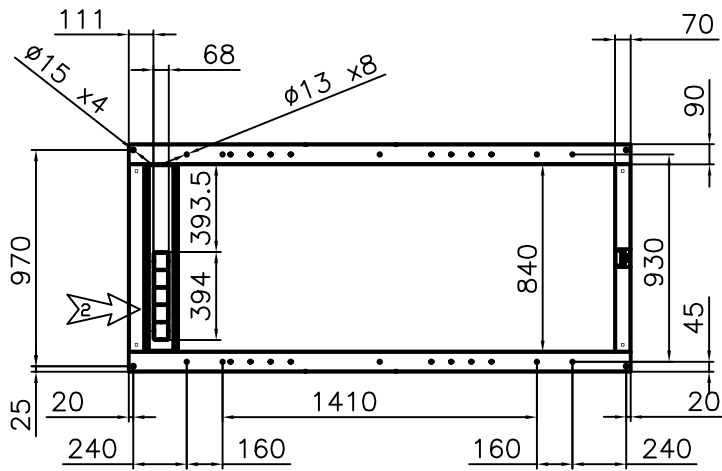

- 1) Ingresso Aspirazione Aria
Air Inlet
- 2) Ingresso cavi
Stub up area
- 3) Espulsione Aria e fumi di scarico
Air and muffler exhaust
- 4) Oblò per rifornimento serbatoio urea
Porthole for urea tank filling

CODICE	DESCRIZIONE	FINITURA	CODICI GESTIONALI CORRISPONDENTI					SPECIFICA
TOLLERANZE GENERALI classe c UNI-EN 22768/1								
3+6	6+30	30+120	120+400	400+1000	1000+2000			
± 0.3	± 0.5	± 0.8	± 1.2	± 2	± 3			
SPESSORE							GENMAC	
MATERIALE							DISEGN.:LRL DATA: 02.12.22	
DESCRIZIONE		INSTALLATION DRAWING QUEEN G80IS-M5					SCALA: A2	
							N° DISEGNO	

I disegni sono proprietà intellettuale di GENMAC e non possono essere riprodotti o diffusi senza permesso scritto dalla GENMAC S.p.A.