

100CZ42.2

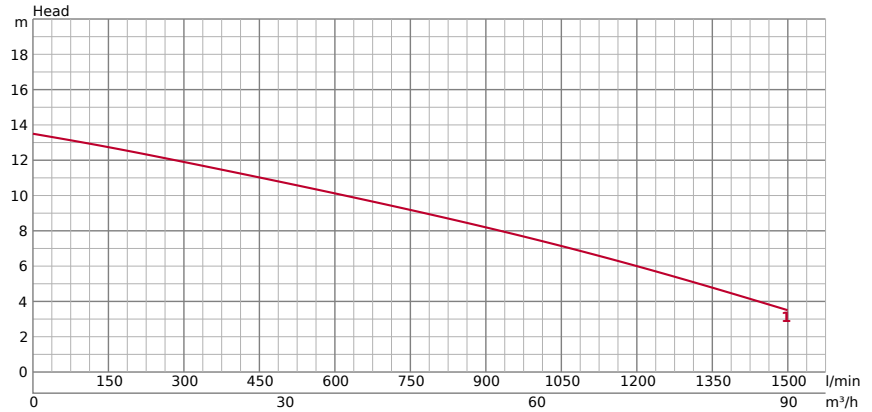

TECHNICAL INFORMATION

GENERAL	Ø Discharge bore mm	100mm	PUMPING FLUID	Type of Fluid	Sewage
	Discharge Connection	Inside thread, JIS10K flange		Temperature	0-40°C
			Max. Solid Handling mm	30	
			Max. PH Value	5-9	
			Max. Capacity l/min	1500	
			Max. Head m	13.50	

PUMP	COMPONENTS		MATERIAL	
	Impeller	Scissor Smasher	Impeller	Ductile iron casting EN-GJS500
	Bearings	Shielded ball bearings	Casing	Grey iron casting EN-GJL-250
	Mechanical Seal	Dual mechanical seal in oil bath	Suction Plate	Ductile iron casting EN-GJS-500-7
			Pump Body	Grey iron casting EN-GJL-200
			Mechanical Seal	Silicon Carbide

TECHNICAL INFORMATION | Motor, Others on the next page →

MOTOR	Motor output kW	2,2	MATERIAL	
	Starting method	direct online	Frame	Grey iron casting EN-GJL-200
	Suitable for VFD	Yes	Shaft	Stainless steel EN-X30Cr13
	Suitable for Soft Starter	Yes	Cable	NSSHÖU 4C*1. 5mm ²
	Type, Poles	Induction motor, 4 poles, IP68	Cable Length	10m
	Insulation	Insulation class F		
	Phase / Voltage	3-phase / 400V / 50Hz		
	r.p.m.	1427		
	Motor Protector (built-in)	Circle thermal cut-out		
	Rated Current	4.80		

OTHERS	Dry Weight Kg	81
	Pressure Resistance	max. 30m

DIMENSIONS

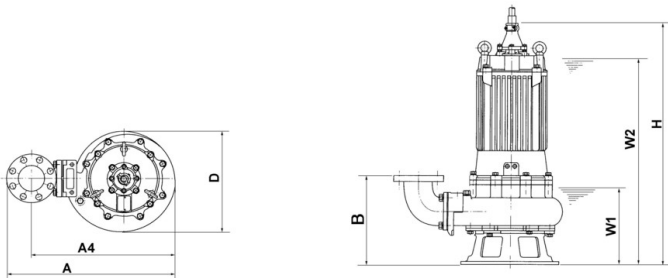

DIMENSIONS - IN MM

A	629	D	341	W1	245
A4	524	H	658	W2	620
B	342				

DIMENSIONS | GUIDE RAIL FITTING TYPE

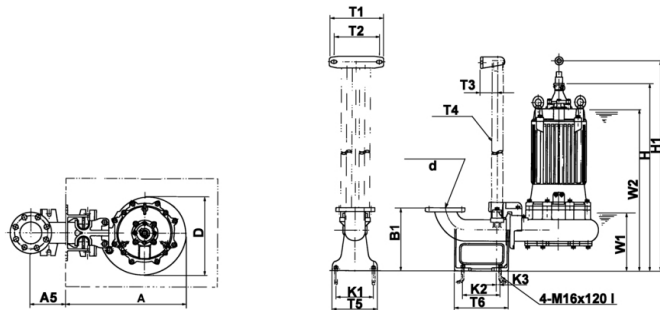

DIMENSIONS | GUIDE RAIL FITTING TYPE - IN MM

A	517	H	659	W1	245
A5	165	H1	782	W2	620
D	334				

PERFORMANCE CURVE

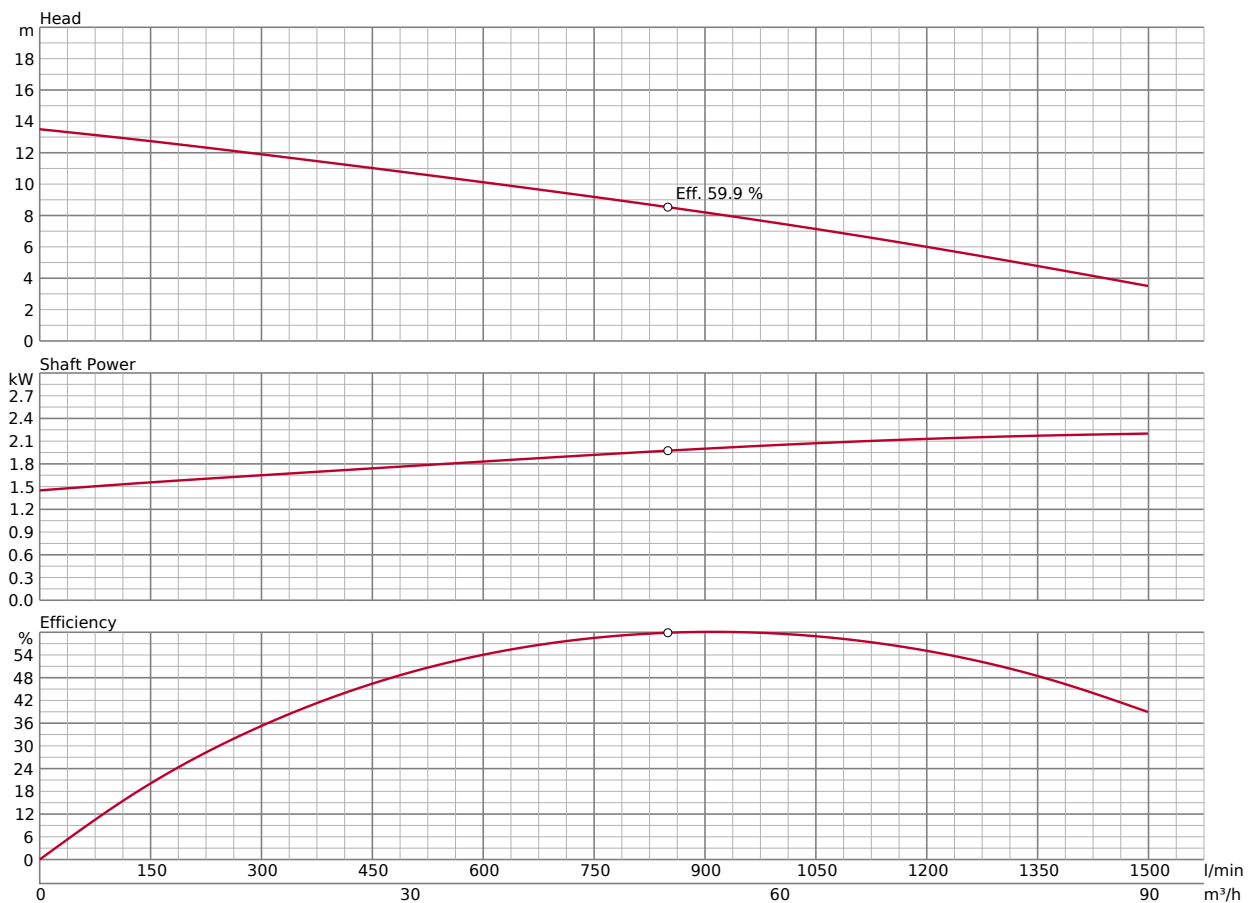

Please mind: discharge bend, duck foot bend and stand set are accessories and must be ordered separately

ACCESSORIES

FREE STAND INSTALLATION KIT (U)XIBEND4T BEND 80-100

Discharge/elbow for vertical pumping



FREE STAND INSTALLATION KIT XISTN4A1 STAND SET 4 A (*5)

Device for free standing installation

GUIDE RAIL FITTING SYSTEM (U)XITOS381TA TOS3-80-100

TOS is the basic guide-rail fitting system for Tsurumi pumps up 150mm discharge bore.

