

Data sheet KTZ611-53

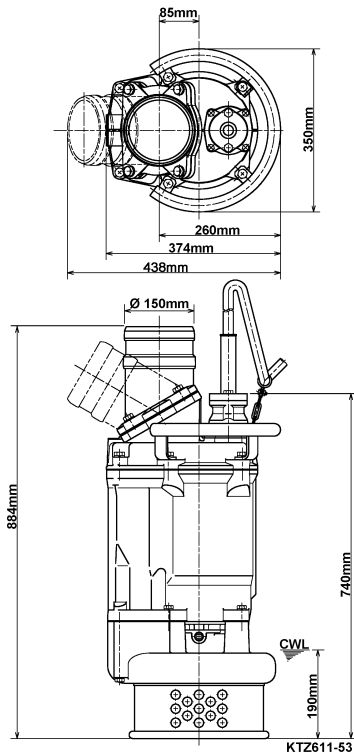

CWL: Continuous running water level

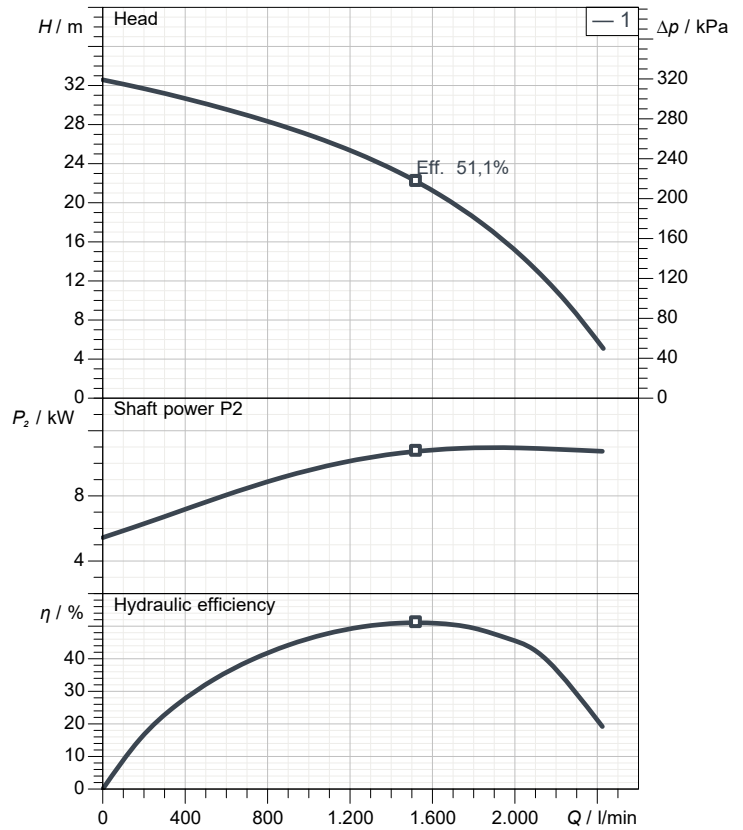

Specification

Electric submersible pump KTZ-series
 Degree of protection IP 68
 Pressure resistance max. 25 m
 Type of impeller Semi-open
 Max. solid handling 20 mm
 Suitable for:
 spring-/rain-/waste-/ground water, water containing sand

Electric motor

Dry-type submersible induction motor
 Insulation class F 2Poles 2.935 1/min
 Starting mode Direct starting
 Rated voltage 400 V 50 Hz 3~
 Power uptake 13,80 kW
 Rated power 11,00 kW
 Rated current 22 A
 Start current 152,9 A

Cable

20m NSSHÖU 4Cx4mm²

Motor Protection

Circle thermal protector
 (snap-action bi-metal device)

Shaft seal

Double inside mechanical seal in oil bath
 additional lubrication by oil lifting device
 Primary seal
 Silicon carbide on silicon carbide
 Secondary seal
 Silicon carbide on carbon

Bearings

Shielded ball bearings, maintenance-free

Materials

Impeller	Chromium Iron HiCrFC
Pump casing	FC200 (EN-GJL-200)
Suction cover	FCD50 (EN-GJS-500-7)
Motor Frame	FC150 (EN-GJL-150)
Shaft	SUS420J2 (EN-X30Cr13)

Discharge size

6" (150mm) BS-Coupling / Hose Coupling (optional)

Weight

131 kg (dry weight of the pump only without cable)

Performance curve

KTZ611-53

Discharge port	6"
Head	32,6 m
Flow	2.429,2 l/min
Rated power	11,00 kW
Power input	13,80 kW
Phases	3~
Voltages	400 V
Frequency	50 Hz
Rated current	22 A
Starting current	152,90 A
Number of poles	2
Speed	2.935 1/min
Starting mode	Direct starting
Insulation class	F

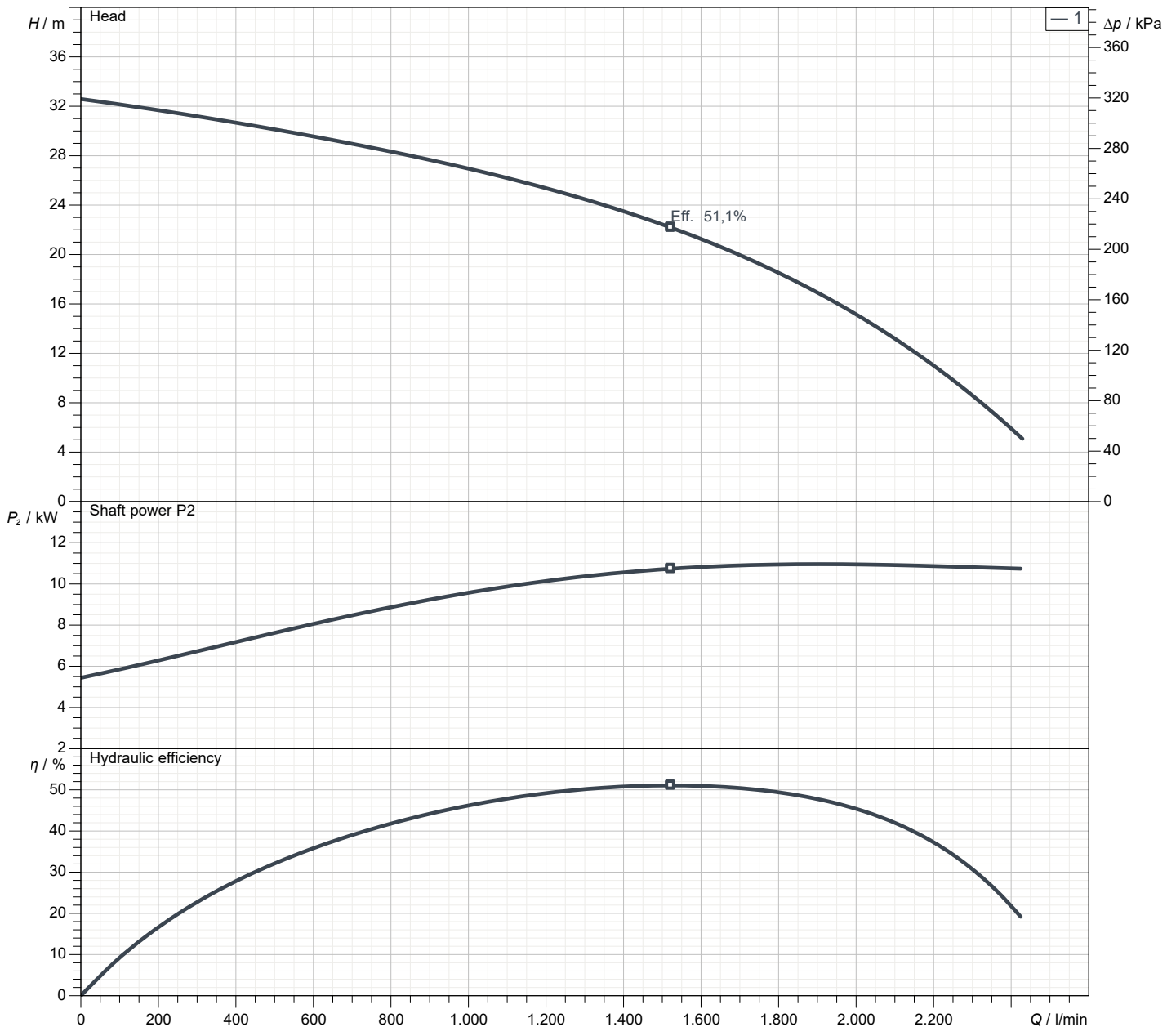

Dimensions

KTZ611-53

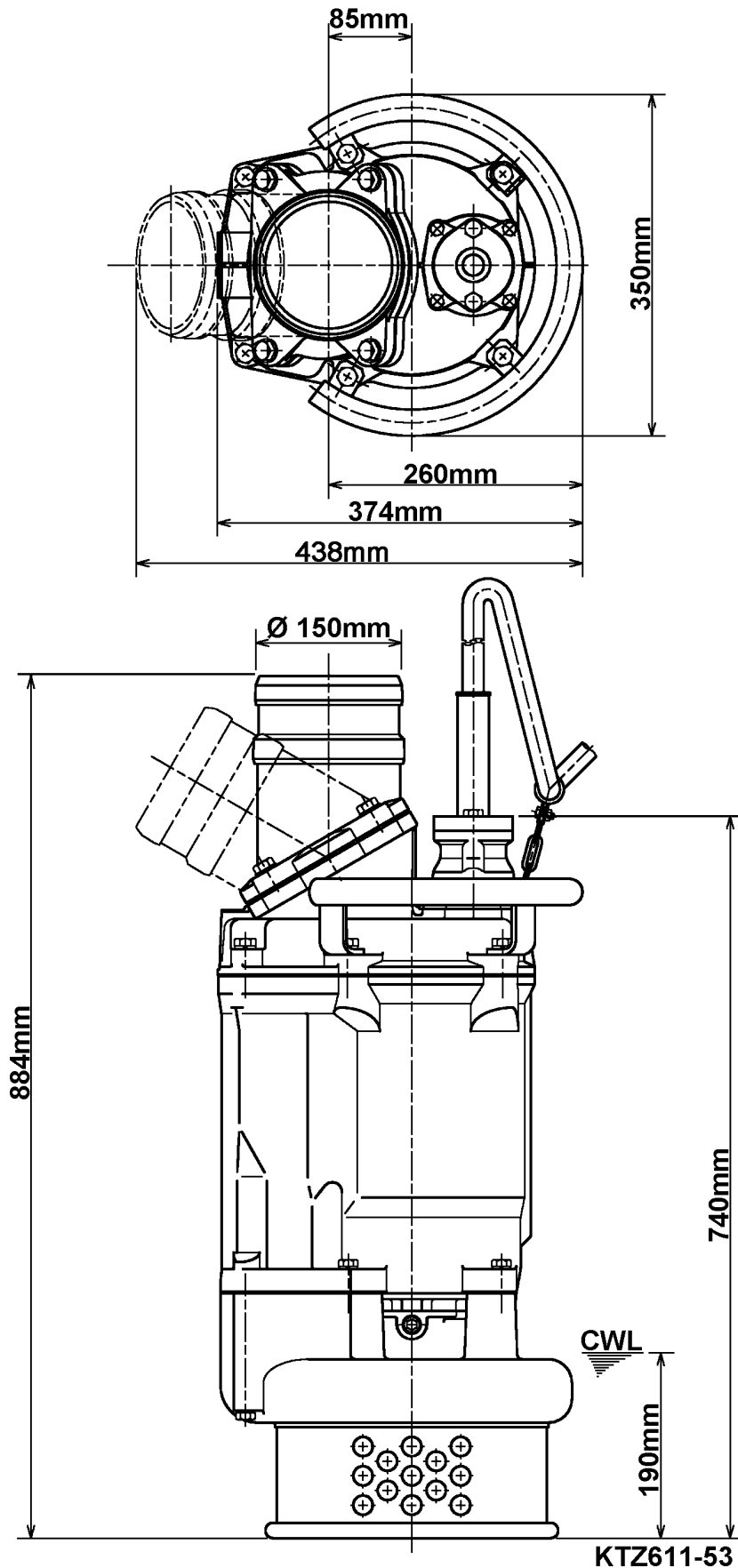

CWL: Continuous running water level
LWL: Lowest running water level

Sectional drawing KTZ611-53

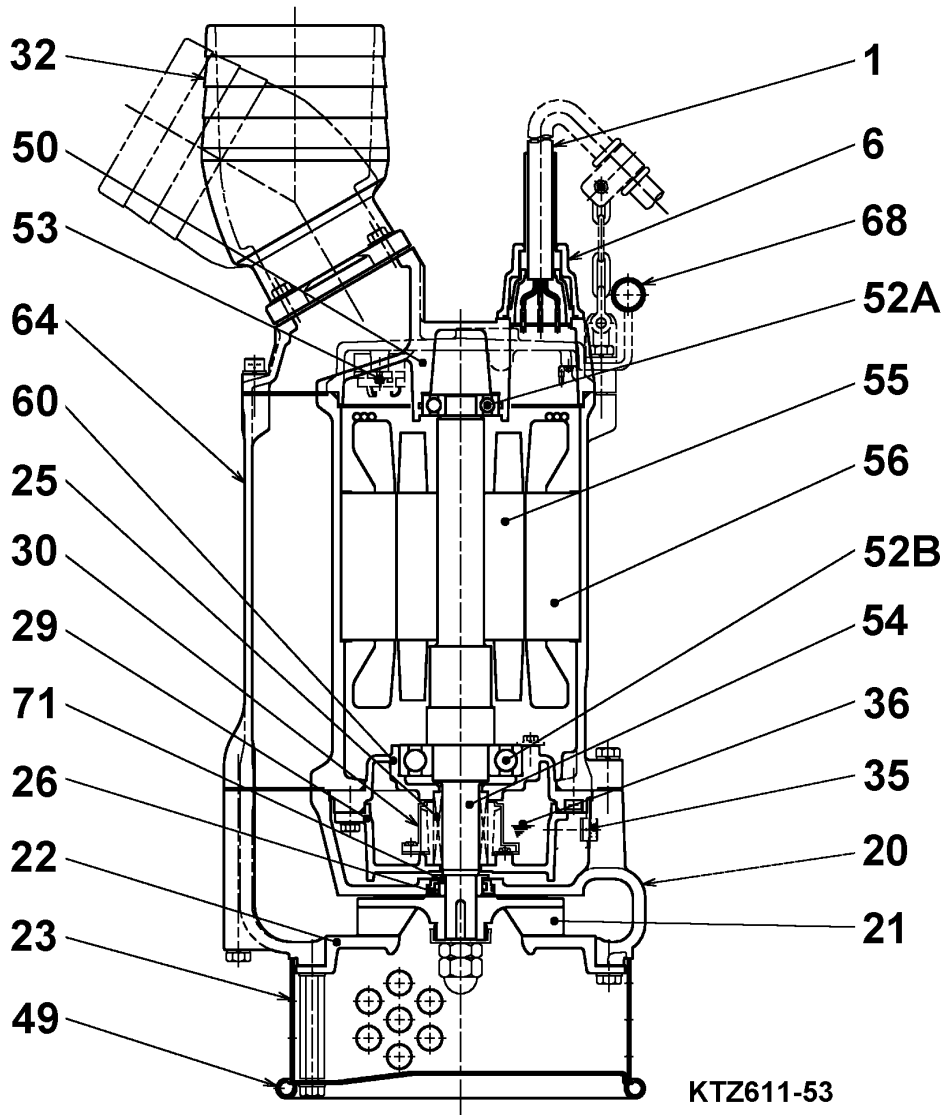

KTZ611-53

No.	Description	Remark	No.	Description	Remark
1	Cable	20m NSSHÖU	52B	Lower bearing	6309ZZC3
6	Stuffing box	FC200 (EN-GJL-200)	53	Motor Protector 380/400/415V-50Hz	KA314-HRXL00 (H.C)
20	Pump casing	FC200 (EN-GJL-200)	54	Shaft	SUS420J2 (EN-X30Cr13)
21	Impeller	Chromium Iron HiCrFC	55	Rotor	.
22	Suction cover	FCD50 (EN-GJS-500-7)	56	Stator	.
23	Strainer	Steel plate	60	Bearing Housing	FC150 (EN-GJL-150)
25	Mechanical seal	HT-3035N	64	Motor Frame	FC150 (EN-GJL-150)
26	Labyrinth ring only	SUS304 (EN-X5CrNi18-10)	68	Handle	steel pipe / Sectional steel
29	Oil casing	FC200 (EN-GJL-200)	71	Shaft protection sleeve	SUS403 (EN-X6Cr13)
30	Oil distributor	Plastic			
32	Discharge coupling	FC200 (EN-GJL-200)			
35	Oil screw	SUS304 (EN-X5CrNi18-10)			
36	Lubricant	Turbine oil (ISO VG32)			
49	Bottom Plate	Steel plate SPCC			
50	Main cover	FC150 (EN-GJL-150)			
52A	Upper bearing	6306ZZC3			